



Tractor Solutions



www.hydraforce.com

Auxiliary Functions

Hitch Release with Power Lift

Flow Sharing

Load Sense

Hitch Control



TECHNOLOGY AND TRACTORS

HydraForce hydraulic controls can enhance the capability of any tractor, from the most basic, value models to the top-of-the-line models equipped with the latest and most sophisticated options.

With our comprehensive line of cartridge valves, manifolds, and high performance electronic

controls, HydraForce can provide numerous custom control solutions for tractors.

This brochure illustrates easy ways to apply electrohydraulics on tractors that will improve performance, increase efficiency, reduce fuel consumption, reduce operator fatigue, minimize vibration and ensure machine safety.



Electronic Control

Programming

EH Boost

Precise Control

Accumulator Charging

CONTENTS

POWERTRAIN-PAGES 4-5

Transmission, lube control, PTO control, cooling, clutch

SUSPENSION SYSTEMS-PAGES 6-7

Front axle, cab seat

PRIMARY FUNCTIONS- PAGES 8-9

Brakes, hitch control, accumulator charging, steering

AUXILIARY FUNCTIONS-PAGES 10-11

Hitch release with power lift, hydraulic power take-off with flow sharing, load sense EH-boost

THE HYDRAFORCE DIFFERENCE- PAGE 12

Highest quality guaranteed, flexible and responsive

ELECTRONIC CONTROLS-PAGE 13

Rugged and reliable

**POWERTRAIN:
TRANSMISSION AND PTO SOLUTIONS**

Ongoing fuel efficiency and emissions reduction standards continue to drive the demand for more efficient, reliable engines. Precise, customizable controls are needed.

HydraForce offers innovative, proprietary powertrain solutions that will not just meet, but exceed your standards for reliability, efficiency, performance, emissions compliance, fuel economy and system modularity.

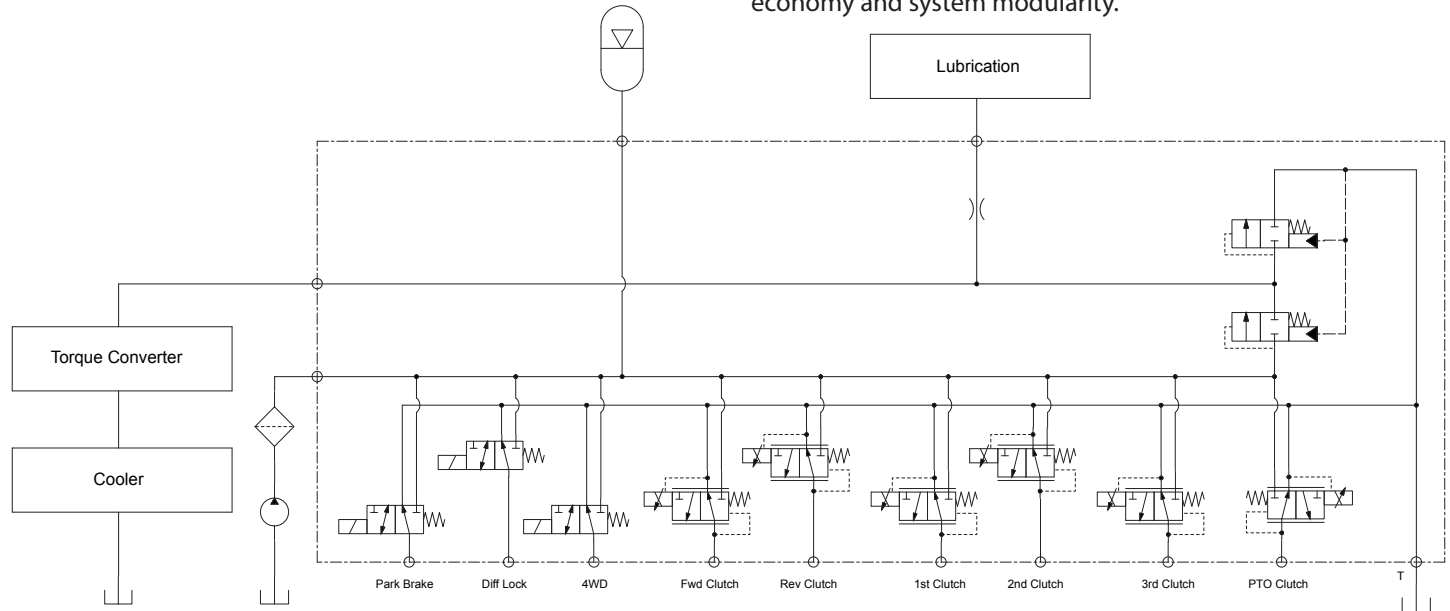

- Variable flow pump controls
- Fuel and oil controls
- Engine brake controls
- Turbocharger controls
- SCR/EGR emission and exhaust controls
- Transmission controls

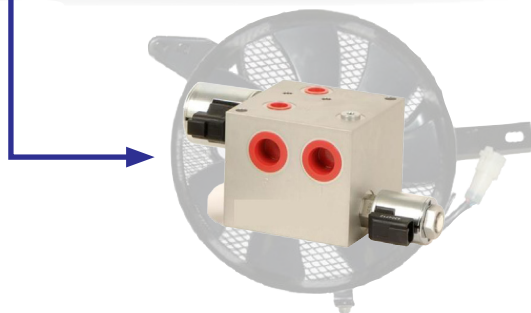
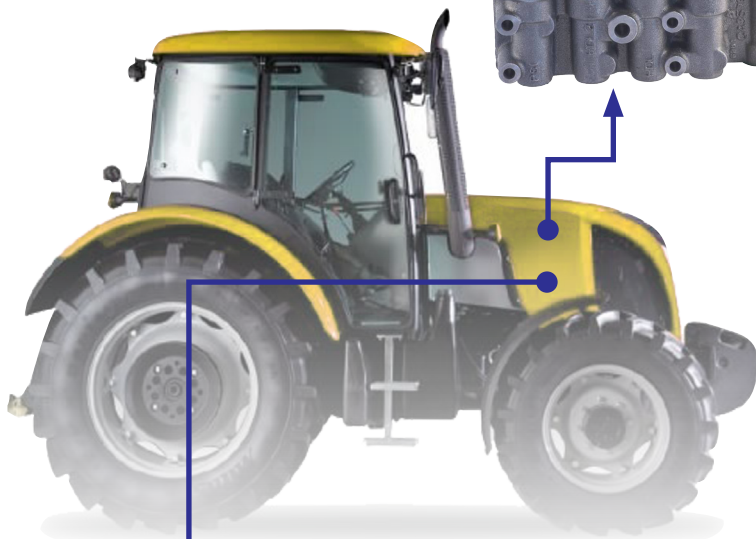

“An electronic control unit can **synchronize** proportional valves... to **regulate** forward, reverse, and multiple clutch actuation with **smooth** and **accurate** control of pressure.”

OPTIMIZE POWERTRAIN SYSTEMS WITH HYDRAULIC CARTRIDGE VALVES AND MANIFOLDS WITH PROGRAMMABLE CONTROLLERS

Synchronize control of transmission clutch, PTO, and fan with a HydraForce electronic control unit. Its programming software is available as a free download from the HydraForce web site. An electronic control unit (shown to the right) can synchronize proportional valves, such as the TS98-T34, to regulate forward, reverse and multiple clutch actuation with smooth and accurate control of pressure. Clutch fill characteristics can be custom-programmed. PTO control can be accomplished with the EHPR98-T38 proportional valve, and fan control with the TS10-27 pressure regulator valve.

Use a Priority Flow Control circuit to give priority to steering and brakes then allow hydraulic flow for other tractor functions, such as plowing, planting, harvesting, loading, or suspension control.

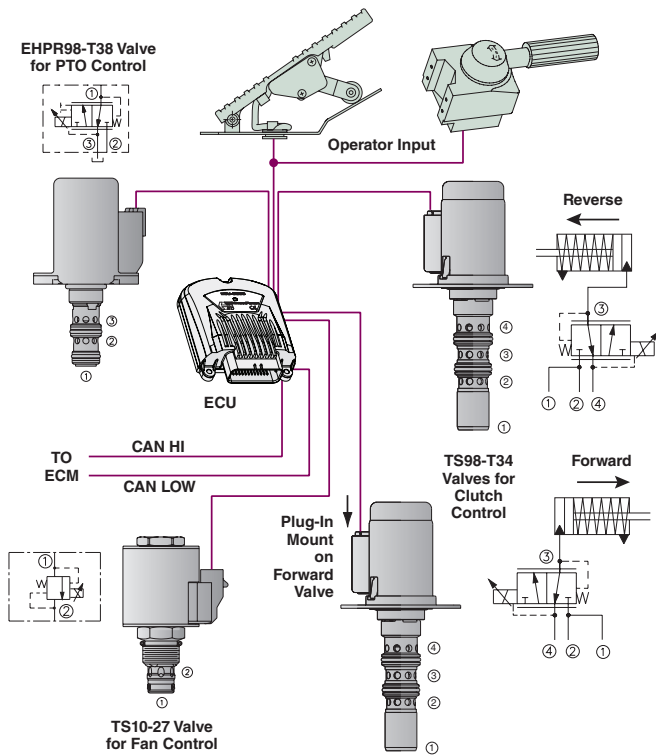

CLUTCH ENGAGEMENT PERFORMANCE (TS98-T34)

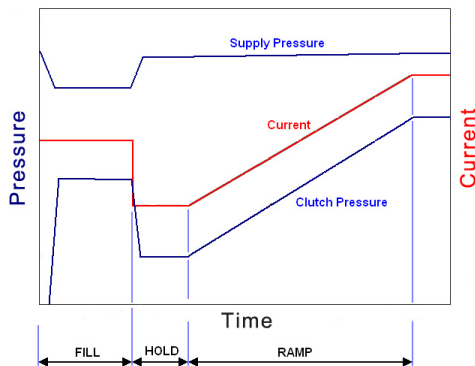

QUIET DOWN THAT FAN...

Fan drives controlled by hydraulic cartridge valves are quieter and run on less horsepower than mechanical fan drives, providing greater fuel economy for tractors.

Control valves with multiple temperature inputs can be used to provide variable fan speed control, depending on air temperature, load, and cooling requirements. If the radiator gets clogged, two-position, four-way solenoid valves can automatically reverse fan direction.

Electronic control of the hydraulic cooling system can be achieved using either an ExDR-type programmable valve driver or an Electronic Control Unit (ECU).

FAN DRIVE SOLUTIONS

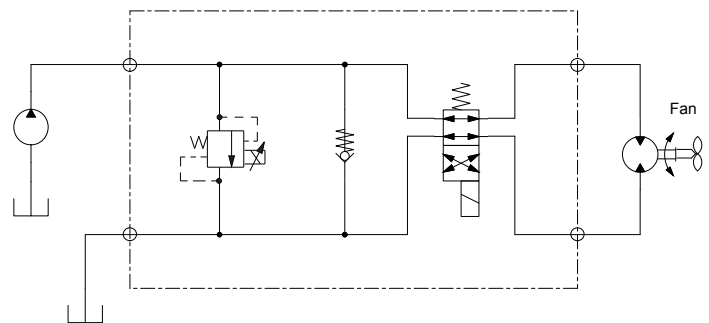

- Flow rates up to 190 lpm (50 gpm)
- Fail safe high or low
- Preconfigured controls available
- Reduce horsepower consumption by up to 30%

FAN OUTPUT PERFORMANCE

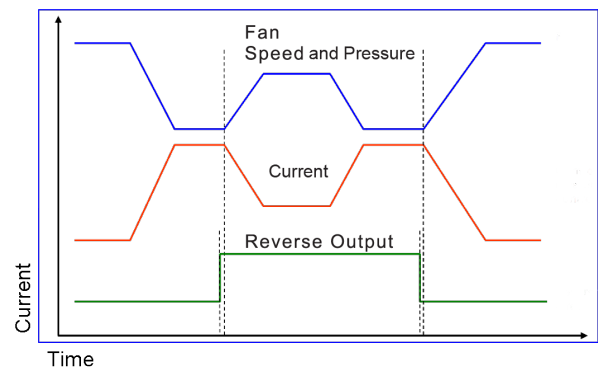

SUSPENSION SYSTEMS

Health and safety consciousness is driving the need for better tractor suspensions. International standards, such as Vibration Directive 2002/44/EC, have heightened awareness of the impact that vibration, stress and shock can have on the driver. Tractor manufacturers are seeking ways to improve seat, cabin, and front axle suspensions – many of these improvements can be made with the use of hydraulic cartridge valves and manifolds.

FRONT AXLE SUSPENSIONS IN TRACTORS

Increased tractor speeds, greater differences and wider ranges of load distribution and terrain have created a resurgence in the use of the suspended front axle to the tractor market.

A hydro-pneumatic suspension system is an effective way to reduce vibration on a suspended front axle. A cartridge manifold is used with an accumulator to keep the cylinder in its nominal position. The accumulator functions as a spring by restricting the oil flow and damping the vibration. With the cylinder in its nominal position, it can extend completely, to its full stroke.

Hydro-pneumatic suspension systems can be further enhanced with the addition of a level control manifold coupled with a position sensor and Electronic Control Unit (ECU). With an enhanced, "intelligent" system, the cylinder can fully complete each stroke, regardless of the load on the axle.

BASIC SUSPENSION SOLUTION

This basic hydro-pneumatic suspension system is ideal for cabin or seat suspension or for tractors with a small axle load range.

- Single or double acting cylinder
- Accumulator
- Level control manifold
- Cartridge valves
- Pressure ratio 1:3 between empty and max loaded axle

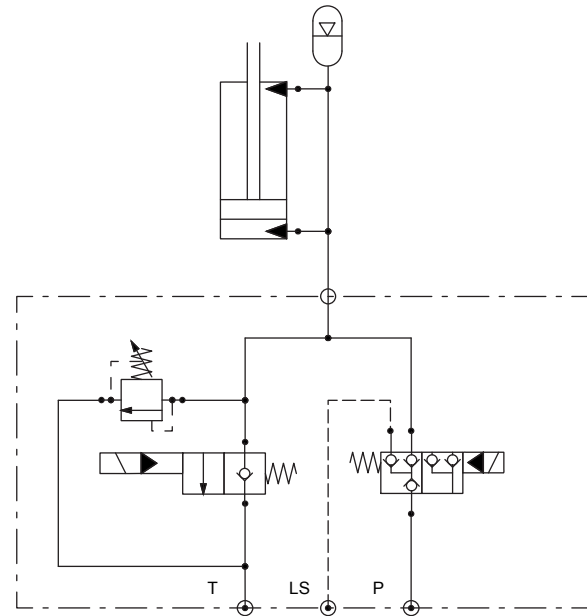

HOW IT WORKS:

Hydro-Pneumatic Suspension Diagram

In a hydro-pneumatic suspension system, a cylinder and accumulator replace the torsion or leaf spring. The accumulator acts as the spring and, with restrictions for oil flow, damping can be accomplished.

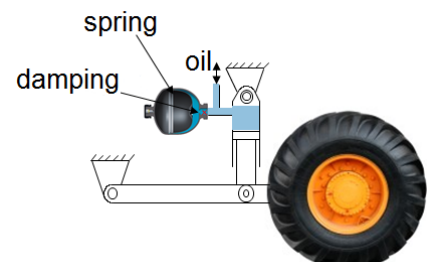
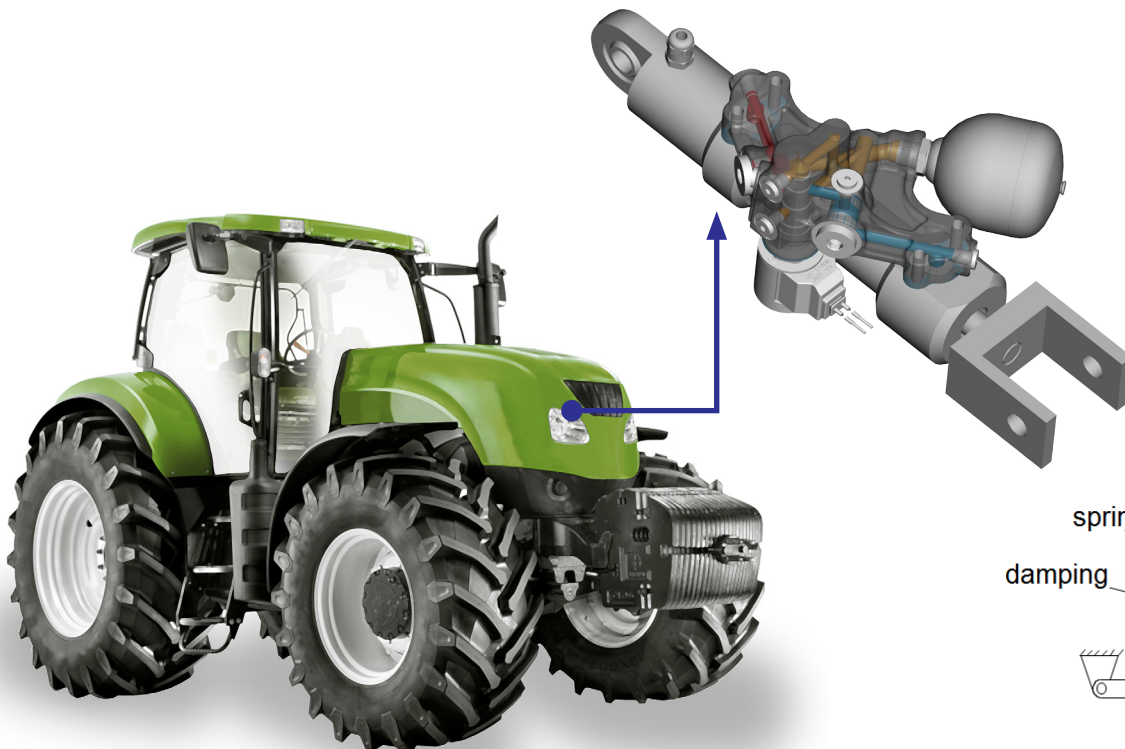

ADVANCED SUSPENSION SYSTEM

Active systems combine variable spring-rate and damping with accelerators and sophisticated software control. This type of adaptable system can achieve a damping profile following the sky-hook principle: performing as if the chassis or cab were magically suspended from the sky.

- Double acting cylinder
- Two accumulators
- Proportional damping valves
- Proportional pressure control valves
- Relief valve
- Position sensor

TSEP PRESSURE CONTROL FOR SUSPENSION SYSTEMS (PATENT PENDING)

Hydraforce offers superior pressure control in the hydro-pneumatic suspension with the multifunction TSEP cartridge. This proportional pressure relief valve with load-holding element performs very accurate control of accumulator charge and therefore spring-rate of the suspension system. With sensors for cylinder stroke, TSEP is also able to control the ride-height dynamically.

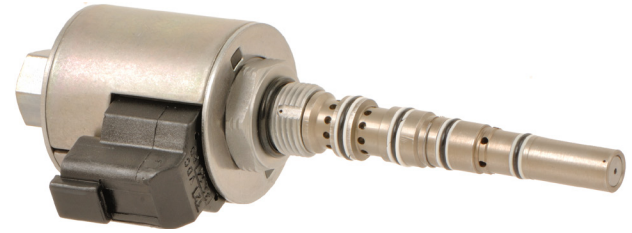
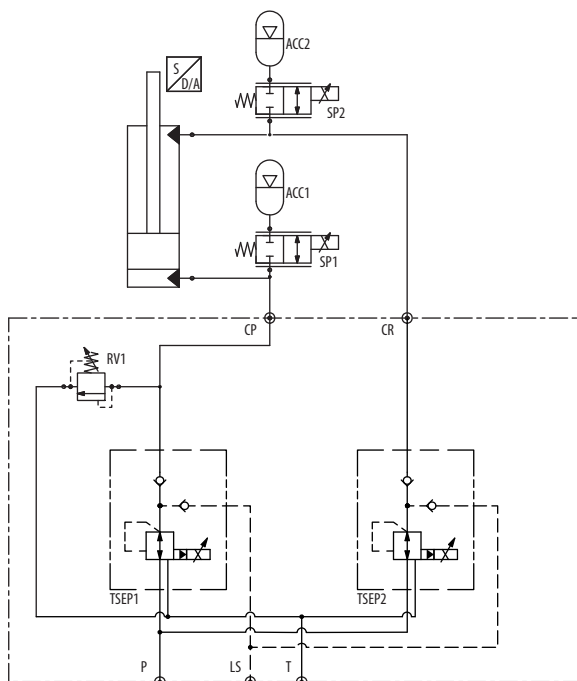

‘Hydraforce offers superior pressure control in the hydro-pneumatic suspension with multifunction TSEP cartridge.’

ROLL STABILIZATION

Cross-connecting suspension cylinders on opposite sides of the vehicle can provide roll stabilization. When cornering, centrifugal forces tend to roll the chassis about its center of mass. Cross-connected cylinders can transfer outboard force to the inboard cylinder leveling the chassis. This offers better performance than the torsional sway-bar.

- Flow path between opposite cylinders.
- Damping orifices.
- Accumulators for spring force.
- Solenoid valve allows feature to be switched on/off.

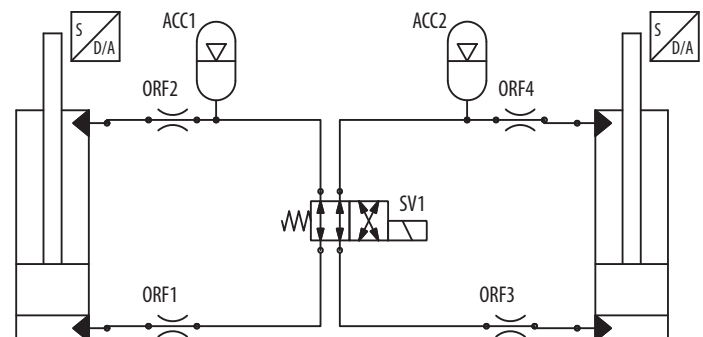

Cross-connecting cylinders adds roll-stability when cornering.

HydraForce offers valves that are well suited to the unique needs of Dynamic Accumulator Charging Circuits. They are commonly used in conjunction with steering and braking units. Hydraulic braking systems are common on tractors and towable implements. These circuits require a delicate balance between the priority flow steering and braking sections of the application, while simultaneously allowing excess flow to be diverted to tank or various auxiliary functions.

A typical circuit provides priority flow for the steering orbital while maintaining a predetermined range of pressure in the accumulator(s), to ensure adequate supply of oil for up to seven brake depressions in the case of power loss. If one accumulator fails, the LS10-41 will shift over to protect the operational one. The ECxx- 42 provides priority flow in required amount while allowing excess flow to be used for auxiliary functions.

“HydraForce
manufactures
a range
of priority on
demand pressure
compensators, with
dynamic
load sensing for
fast
response.”

PRIMARY FUNCTIONS

Primary Functions are the basic/standard control circuits, such as Steering, Braking, and Hitch (Lift) Control.

STEERING/BRAKING

These functions have priority over all other hydraulic demands. HydraForce manufactures a range of priority on demand pressure compensators, with dynamic load sensing for fast response. There are 7 different models of priority on demand pressure compensator valves (ECxx-43). The rated flow capacities range from 34 lpm to 530 lpm (9 gpm to 140 gpm).

DUAL ACCUMULATOR CHARGING

HydraForce Inverted Shuttle Valve LS10-41 provides additional safety when using dual accumulators. In the event of one accumulator failing (e.g. a ruptured bladder, etc.), the failed accumulator is isolated from the rest of the circuit, allowing the second accumulator to supply steering/braking.

PRIMARY STEERING AND BRAKE SOLUTION

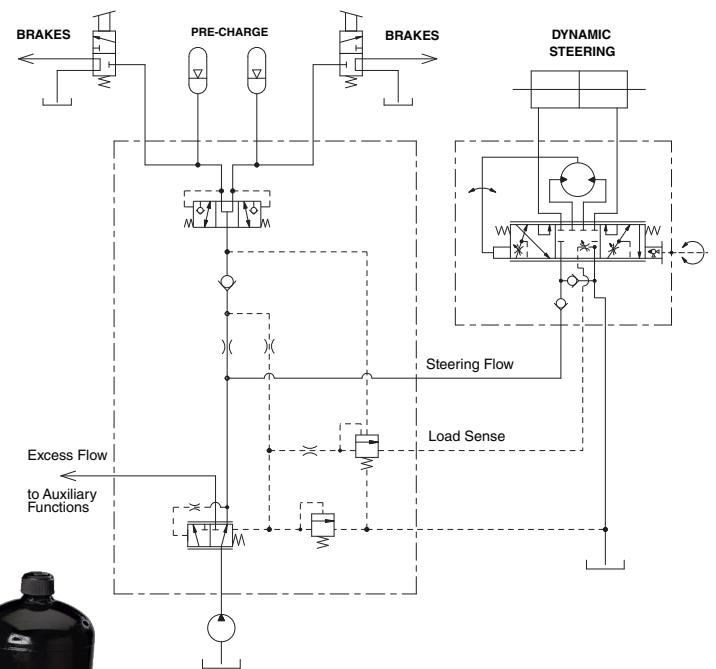

- Primary Flow to the brake section of the circuit
- Auxiliary Flow diverted to the directional function



RVD50-20P, PED-RATED PRODUCT FOR ACCUMULATOR CHARGING CIRCUITS

The RVD50-20P is a direct-acting, poppet type, hydraulic safety relief valve. The RVD50-20P is suitable for use as a safety accessory in Category IV, Group 2 applications according to the pressure equipment directive (PED) 97/23/EC, which is primarily concerned with the protection of accumulator circuits. This is particularly well suited for dynamic brake charging circuits where pressure clipping and quick discharge of energy is often needed.

HITCH (LIFT CONTROL)

As tractor power and sophistication increases, so do the flow rates. HydraForce SPCL16-30 valves gives precise control up to 150 lpm (40 gpm) while holding the loads with extremely low leakage. HydraForce RV10-28 and RVD50-20 relief valves limit the shock pressure peaks while having very low leakage and hysteresis.

“HydraForce SPCL16-30 valves gives precise control up to 150 lpm while holding the loads with extremely low leakage.”

REAR CONTROL LIFT CIRCUIT

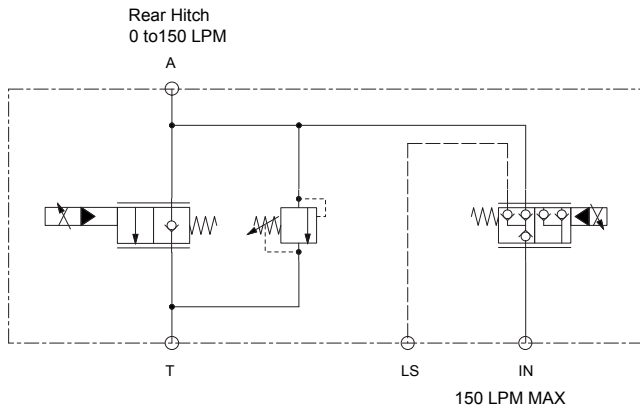

PROPORTIONAL HITCH CONTROL CIRCUIT

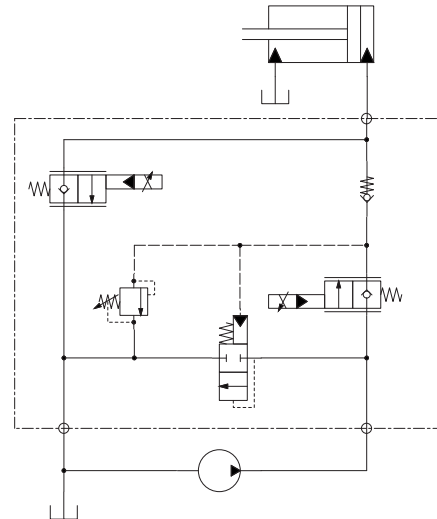

FRONT AND REAR HITCH CONTROL CIRCUIT

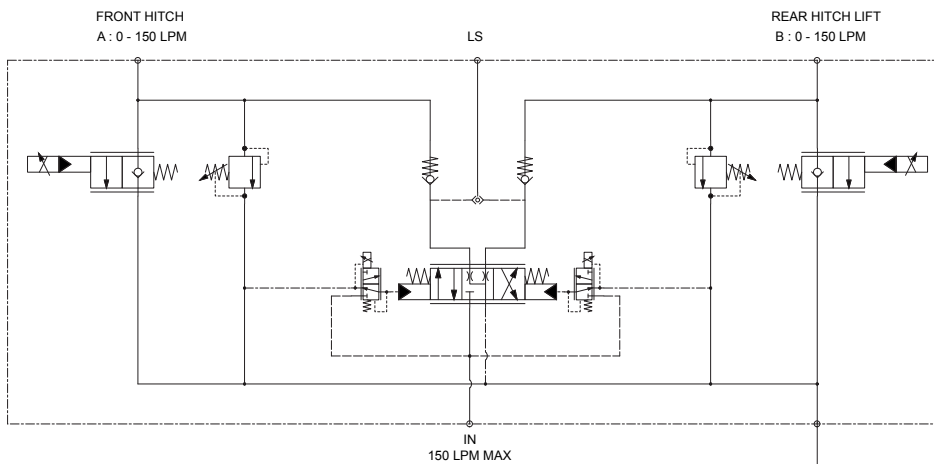

AUXILIARY FUNCTIONS

Control of hydraulic flow for tractor auxiliary functions and trailed equipment can be accomplished efficiently with compact HydraForce cartridge valves. Low-flow piloted systems, or higher flow direct-acting circuits, can be configured and controlled with CAN-based electronics. Here are just a few of the selections available.

G3 "Next Generation" Cartridge Valves

For several decades, HydraForce has designed cartridge valves for pilot controls and powertrain systems. The new, G3 line of cartridge valves represents the "next generation" of controls, building on the best features of the original lines of HydraForce solenoid SV and proportional EHPR and TS valves.

The G3 valves feature a durable actuator with superior magnetic force and low current draw, which improves efficiency and reduces power consumption. Top-mounted connectors are more compact and easier to fit into tight spaces.

A removeable flange makes it easy to specify G3 valves for retrofit or replacement applications where mounting holes must match precisely.

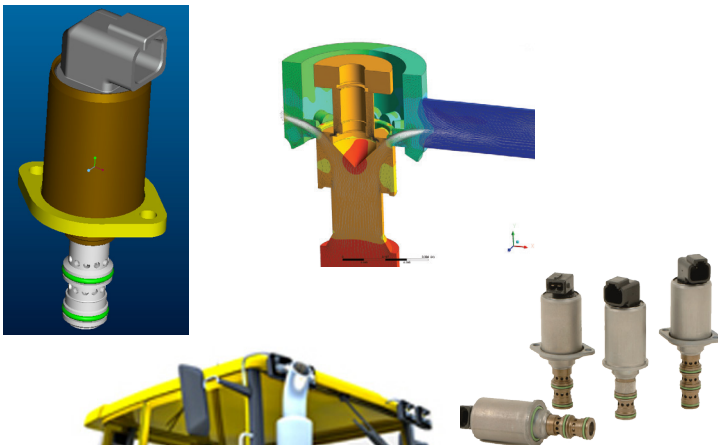

MVPR TRAILER BRAKE VALVES

Synchronize trailer and tractor brakes with the HydraForce MVPR valve, a manually-operated, proportional pressure reducing/relieving valve.

The operating input could be a wire or a lever connected to the brake pedal and you can customize the controlled pressure range.

The controlled pressure is used to operate the trailer brake in synchronization with the tractor brakes.

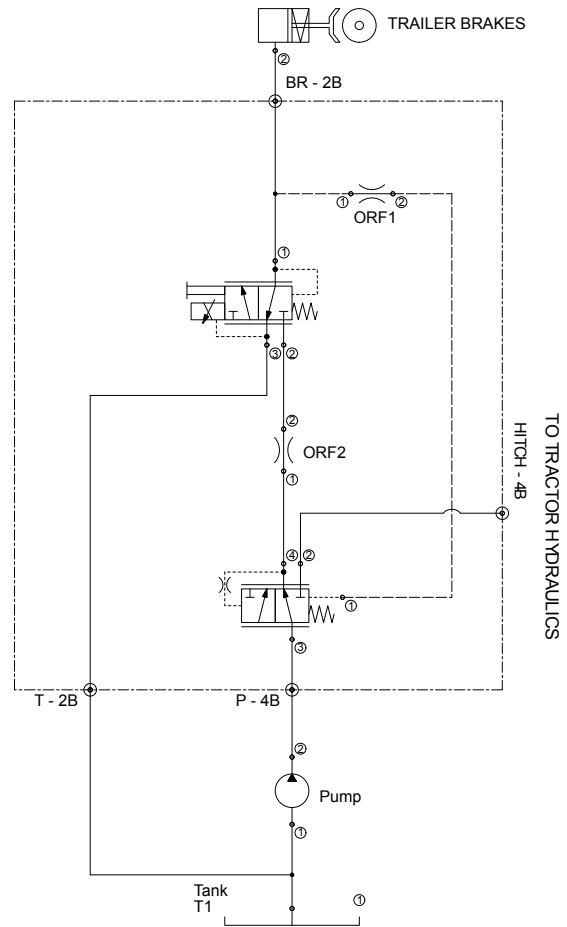
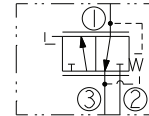

HYDRAULIC POWER TAKE-OFF WITH FLOW SHARING

HydraForce auxiliary function circuits provide precise control of flows for balers, crop harvesters, and other auxiliary equipment.

Higher productivity requires higher flows, and HydraForce cartridge valves can handle flows up to 300 lpm (79 gpm).

When the flow demand exceeds the system supply, flow sharing can help maintain effective control.

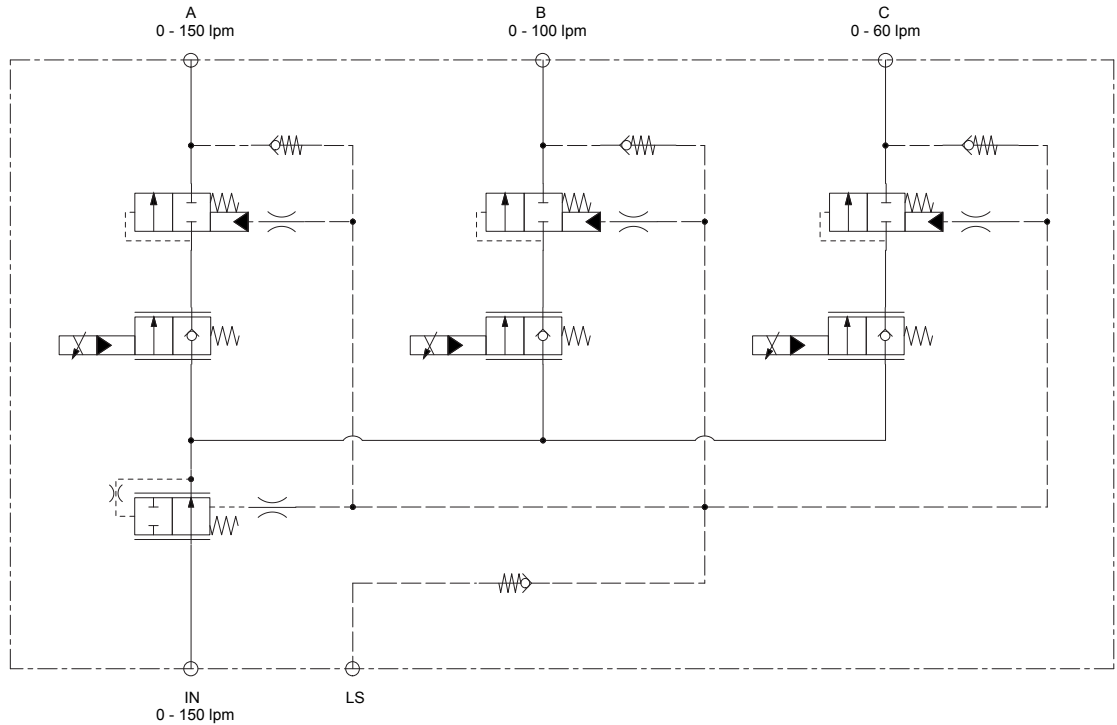

Load Sense Boost

Higher flows and shorter response times are possible with load sense boosting. When lower flows are adequate for the job, reduce standby pressures to save power.

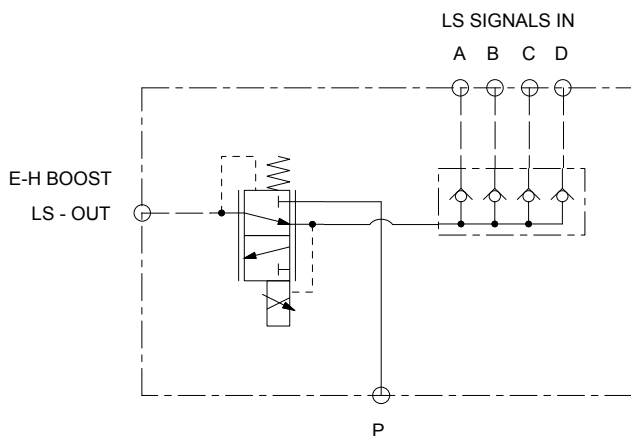

Hitch Release and Power Lift

Positioning and attaching the rear lift hitch attachment from the cab gives increased productivity and improved operator comfort and safety.

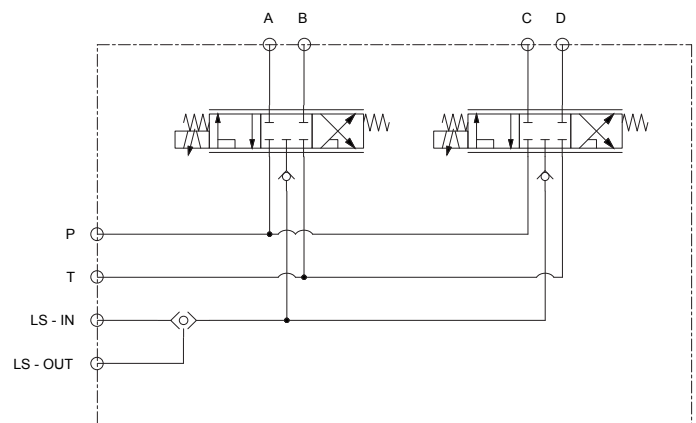

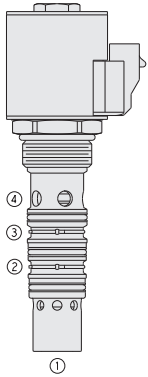

SPCL 16-40

Proportional Directional Control, 4-Port,
Normally Closed with Check Isolated
Load Sense

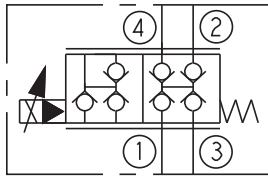

Flow: 152 lpm/40 gpm
Pressure: 250 bar (3625 psi)

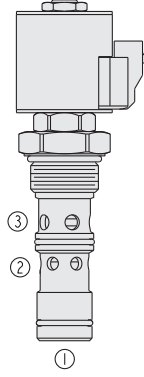

HSPEC16-30

Proportional Flow Control Valve with
Integral Compensator

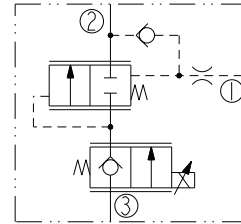

Flow: 132 lpm/35 gpm
Pressure: 350 bar (5075 psi)

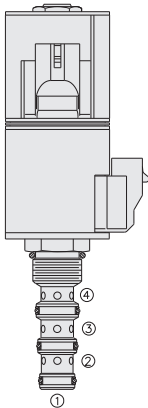

HSV10-47

High Pressure Spool 4-Port, 3-Position,
Closed Center

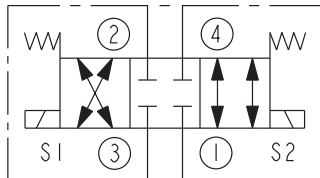

Flow: 37.9 lpm/10 gpm
Pressure: 350 bar (5075 psi)

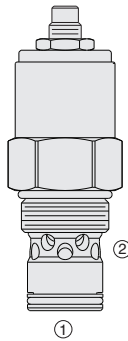

RVCV56-20

Relief, Directing Acting Poppet with
Reverse Flow Check

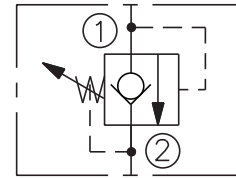

Flow: 115 lpm/30 gpm
Pressure: 420 bar (6100 psi)

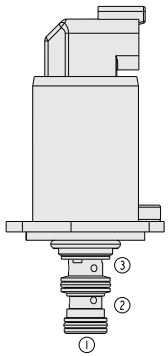

EHPR98-G3X

Proportional, Reducing / Relieving,
Drop-in

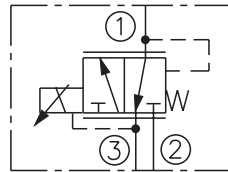

Flow: 4-6 lpm/1-1.4 gpm
Pressure: 20-30 bar (290-435 psi)

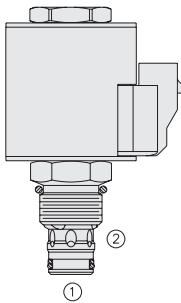

TSxx-27

Proportional Pressure Control,
Pilot-Operated Relief

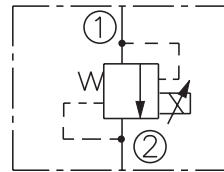

Flow: up to 189 lpm/50 gpm
Pressure: 241 bar (3500 psi)

OUR BREADTH OF PRODUCT

As the largest manufacturer of hydraulic cartridge valves in the world, HydraForce offers an extensive range of solenoid, electro-proportional, directional, flow, and pressure control valves. Last year, more than 200 new valves were introduced, including many high pressure and multi-function models. Cartridge valves for flow rates up to 570 lpm/150 gpm and operating pressures up to 350 bar/5,000 psi are sold individually, with housings or in manifold blocks. Valves can be custom-designed or standard product.

HydraForce designs, manufactures and supports valve, manifold and accessory products supported by heavy duty electronic machine control capabilities.

To request a free hydraulic integrated circuit (HIC) consultation, please visit:

<http://info.hydraforce.com/Free-Custom-Circuit-Consultation/>

“HydraForce
has more
than **600**
standard cartridge valve products”

PROGRAMMABLE MACHINE CONTROLLERS

It's easy to add electronic control to your hydraulic application with the HydraForce line of electronic control units (ECUs) and electronic valve drivers (ExDRs).

HydraForce electronic controllers are designed to withstand the environmental demands of mobile, off-highway equipment applications. With flexible input and output configuration, these versatile controllers can easily be customized for a wide variety of applications, including fan control, generator set control, transmission and timed control applications, and more.



ExDRS-ELECTRONIC VALVE DRIVERS

ExDRs are compact, economical and reliable electronic drivers for proportional solenoid valves. They mount directly onto the solenoid coil and are configurable using *HF-Impulse* software on a computer and serial cable or CAN to USB adapter.

ExDR-0101A

One input and one output. Input can be accepted from analog or digital operator interface devices.

ExDR-0201A

One or two outputs and one input that can be accepted from analog or SAE J1939 operator interface devices.

ExDR-0203A

Feature three configurable inputs and two outputs. This larger valve driver will be able to provide precise, repeatable control of four proportional valves and one on/off solenoid. LED signal will provide quick status check.

ExDR-0506A

Features six configurable inputs and five PWM outputs.

HF-IMPULSE CONFIGURATION SOFTWARE

HydraForce has developed an easy-to-use configuration platform - *HF-Impulse*, available for free download from the HydraForce Electronics Portal at www.hydraforce.com/electronics. *HF-Impulse* allows you to flash devices with the latest firmware and configure all parameters for operation. You can configure a number of HydraForce electronic controllers using *HF-Impulse*.

ECU-ELECTRONIC CONTROL UNITS

Model ECU-2415

Up to 39 digital, pulse, current measuring feedback and analog inputs along with 24 outputs consisting of up to 24 PWM or digital high-side drivers.

Model ECU-2820

Up to 52 inputs and 28 outputs consisting of up to 24 PWM or digital high-side drivers and up to four digital low-side drivers.



ECU 2415 and 2820

Model ECU-0809

Features 8 flexible sourcing outputs, 9 flexible inputs, and 4 feedback inputs. This controller is built on a powerful 32-bit microprocessor and features a diagnostic indicator, unlimited F-RAM and CAN capability.



ECU 0809

SENSOR VALVES

Select HydraForce valves can be ordered with an integral position sensing option capable of transmitting an on or off signal. This simple sensing solution was designed for interchangeable use with existing HydraForce cartridge valves, is compatible with manual override options and uses an industry standard cavity.

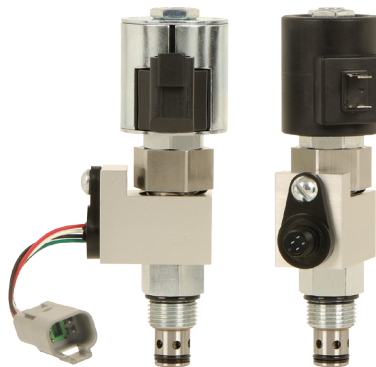

HEAVY DUTY SENSORS

HydraForce has accurate sensors designed for off-road applications.

ERT 120 Temperature Sensor (left)

Our temperature sensor is thermistor style with padded resistors and an output signal between 5427.9 to 436.3 ohms.

ERP Pressure Sensor (right)

Our pressure sensors have 1% total error band accuracy, are IP67 rated.

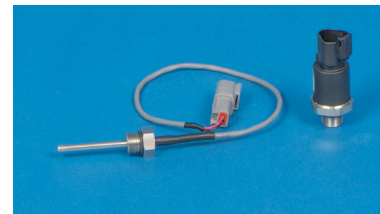

ERP035 – for pressure ranges up to 35 bar (500 psi)

ERP414 – for higher pressures up to 414 bar (6000 psi)

OUR STORY

The HydraForce story began in 1985 when the company was founded near Chicago by several partners who saw the mobile equipment industry's need for quality hydraulic cartridge valves and manifolds delivered in a timely and responsive manner. They also saw the potential for engineering innovation and design flexibility offered by cost-effective and space-saving cartridge valves and hydraulic integrated circuits.

Since its founding, HydraForce continues to be a privately held company as it has grown to several manufacturing locations in North America, Europe and Asia, with a network of 120 stocking distributors who can offer local support across the globe.

To maintain our core competency of speed to market, HydraForce has invested in application technical support tools including i-Design, our free hydraulic system design software, which integrates seamlessly with 3rd party simulation software, monthly webinars on new products and application tips, and an online product catalog. All HydraForce products carry a five-year limited warranty against defects in material and workmanship.

OUR QUALITY AND MANUFACTURING GUARANTEE

All three HydraForce plants in North America, Europe and Asia follow the same manufacturing processes and standards to ensure global consistency in product quality.

- All products 100% tested
- Use of Lean and Six Sigma practices
- New product introduction tools such as:
 - Advanced Product Quality Planning (APQP)
 - Production Part Approval Process (PPAP)
 - Failure Mode and Effect Analysis (FMEA)
 - Statistical Process Control (SPC)
- Continuous improvement through Kaizen
- Responsive delivery with Kanban throughput system



OUR VISION:
“To be
an independent
provider of
innovative
technical solutions that can
change the
world.”

OUR MISSION:
“To provide our customers
with the highest
quality hydraulic
valves
and the most responsive
customer support
in the world.”

HYDRAFORCE TIMELINE

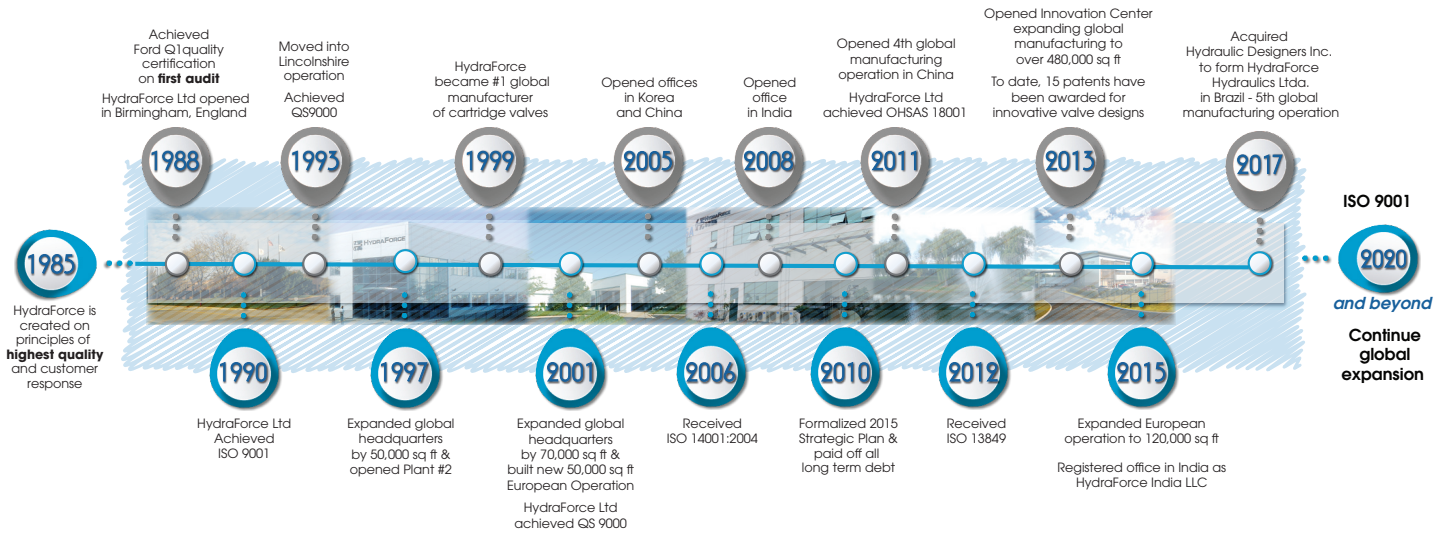

WORLDWIDE SUPPORT



WHY CONSIDER HYDRAFORCE?



- World's largest privately owned cartridge valve manufacturer focused on EH system controls
- Broadest range of cartridge valves
- Designed EH systems for mobile equipment in every industry



- Integrate sensors, fittings, ancillary valves, and other custom components into a single manifold
- Simplified circuit design
- Consolidated or distributed hydraulic systems

- All manifolds are end-of-line function tested
- Use of Lean and Six Sigma practices
- Five year warranty on valves and manifolds



RoHS COMPLIANT HydraForce valve and manifold products comply with the European Council and Parliament RoHS directive 2002/95/EC limiting the use of hazardous substances. For all other products, consult factory.

The content of this document implies no warranty of merchantability or fitness for a particular purpose. This information provides technical illustration only and is not a statement of suitability for any particular application. Each application is unique and we advise you to conduct your own tests and studies to determine the fitness of our products for your application.

© Copyright 2017 HydraForce, Inc. All rights reserved. HydraForce and the HydraForce logo are registered trademarks of HydraForce, Inc.

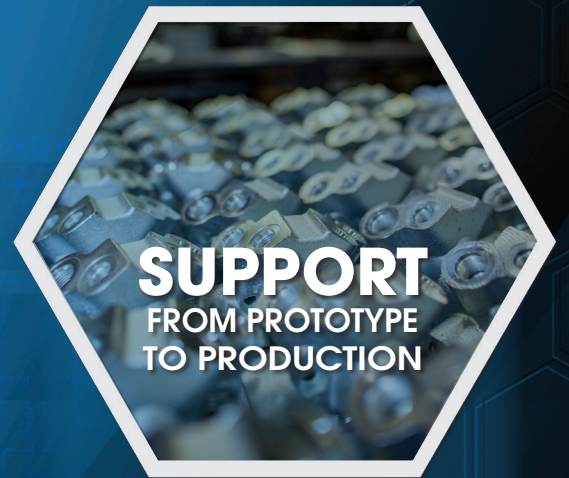

- Free design support
- Simulation software
- Fast prototypes

