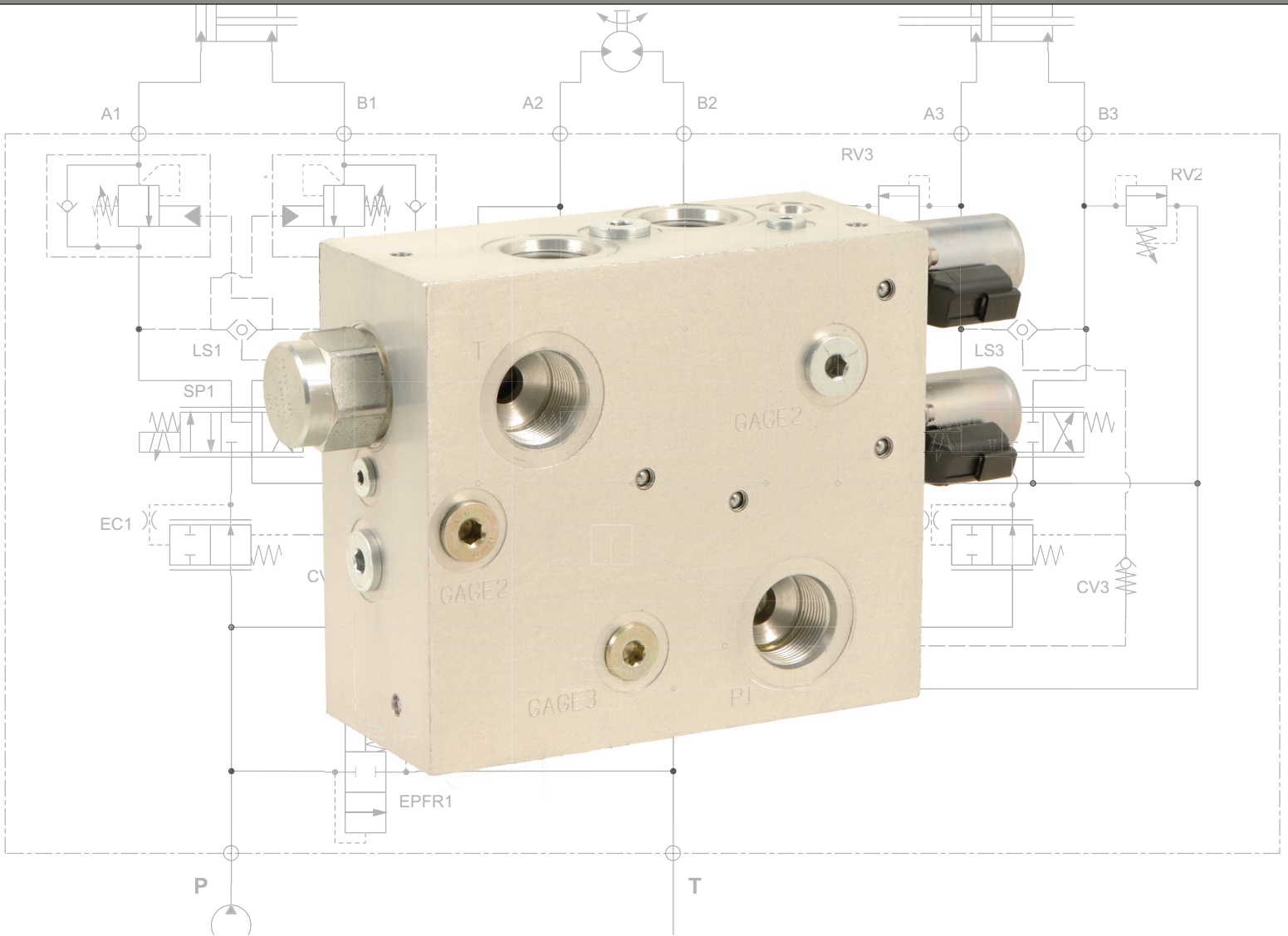


# HYDRAFORCE

## POWER FORWARD



# INTEGR8

ENGINEERED HYDRAULIC CONTROL SOLUTIONS

[www.hydraforce.com](http://www.hydraforce.com)

# Table of Contents

## INTRODUCTION

Table of Contents .....	00.00.02
Safety .....	00.00.03
How to Use This Catalog .....	00.00.04
Engineered Control Solutions.....	00.00.05

## FLOW CONTROL CIRCUITS, PRESSURE-COMPENSATED

### Direct-Acting

Theory of Operation, Schematic .....	00.02.01
<b>Normally Closed (SPxx-20x).....</b>	<b>00.02.10</b>
Schematic, Application Tips, Description, Operation, Features, Ratings, Performance Charts, Ordering Information	
<b>Normally Open (SPxx-21x).....</b>	<b>00.02.14</b>
Schematic, Application Tips, Description, Operation, Features, Ratings, Performance Charts, Ordering Information	

## DIRECTIONAL CONTROL CIRCUITS, PRESSURE-COMPENSATED

### Direct-Acting

Directional Control Valves - Getting Started ..	00.02.30
Theory of Operation, Schematic .....	00.02.31

### CYLINDER CIRCUITS, Direct-Acting

<b>Meter-In/Out (SPxx-47C) .....</b>	<b>00.02.40</b>
Schematic, Application Tips, Description, Operation, Features, Ratings, Performance Charts, Ordering Information	

### MOTOR CIRCUITS, Direct-Acting

<b>Meter-In/Out, Non-Restricted (SPxx-47D) ..</b>	<b>00.02.50</b>
Schematic, Application Tips, Description, Operation, Features, Ratings, Performance Charts, Ordering Information	

### Pilot-Operated

Getting Started - Load Sense Basics .....	00.04.01
Theory of Operation, Schematic .....	00.04.02

## CYLINDER CIRCUITS, Pilot-Operated

<b>Meter-In/Out (PExx-S67C).....</b>	<b>00.04.10</b>
Schematic, Application Tips, Description, Operation, Features, Ratings, Performance Charts, Ordering Information	

## MOTOR CIRCUITS, Pilot-Operated

<b>Meter-In/Out, Non-Restricted (PExx-S67D) ...</b>	<b>00.04.12</b>
Schematic, Application Tips, Description, Operation, Features, Ratings, Performance Charts, Ordering Information	

## Meter-In/Out, Restricted (PExx-S67H) .....

<b>00.04.14</b>	
Schematic, Application Tips, Description, Operation, Features, Ratings, Performance Charts, Ordering Information	

## Meter-In, Non-Restricted (PExx-S67K) .....

<b>00.04.16</b>	
Schematic, Application Tips, Description, Operation, Features, Ratings, Performance Charts, Ordering Information	

## DETAILED SPECIFICATIONS

<b>Solenoid Operated On-Off Valves.....</b>	<b>Section 1</b>
<b>Electro-Proportional Valves .....</b>	<b>Section 2</b>
SP08-20.....	2.008.1
SP08-20A .....	2.009.1
SP10-20 .....	2.010.1
SP10-20A .....	2.010.1
SP12-20 .....	2.012.1
SP12-20A .....	2.012.2
SP08-21 .....	2.020.1
SP08-21A .....	2.020.1
SP10-21 .....	2.021.1
SP10-21A .....	2.021.1
SP12-21 .....	2.022.1
SP12-21A .....	2.022.1
SP08-47C .....	2.110.1
SP10-47C .....	2.112.1
SP08-47D .....	2.120.1
SP10-47D .....	2.122.1
<b>Directional Valves.....</b>	<b>Section 4</b>
HCV06-20 .....	4.008.1
HCV08-20 .....	4.010.3
HLS06-30.....	4.266.1
HLS06-B30.....	4.267.1
PE12-S67C .....	4.416.1
PE12-S67D .....	4.424.1
PE12-S67H .....	4.428.1
PE12-S67K.....	4.436.1
<b>Flow Control Valves .....</b>	<b>Section 5</b>
EC08-32.....	5.418.1
<b>Pressure Control Valves .....</b>	<b>Section 6</b>
RV08-20.....	6.010.1
<b>Warranty .....</b>	<b>Section 9</b>

### FIVE-YEAR LIMITED WARRANTY

All HydraForce products carry a five-year limited warranty against defects in material and workmanship.

For full warranty information see page the last page of this catalog.

### WARNING



**READ THIS DOCUMENT BEFORE INSTALLING OR USING HYDRAFORCE PRODUCTS. IMPROPER SELECTION, IMPROPER USE, USE BY ANYONE OTHER THAN TRAINED USERS HAVING APPROPRIATE TECHNICAL AND MECHANICAL EXPERTISE, OR FAILURE OF HYDRAFORCE PRODUCTS OR RELATED ITEMS RESULTING THEREFROM CAN CAUSE DAMAGE TO EQUIPMENT OR PROPERTY, SERIOUS PERSONAL INJURY, OR DEATH.**

This document and other information from HydraForce, its subsidiaries and authorized distributors (collectively “HydraForce”) together only provide product installation guidelines and product or system usage options, each of which are intended to operate in conjunction with further investigation by trained users having appropriate technical and mechanical expertise to facilitate the safe handling and use of HydraForce products. HydraForce products are not intended to be used or handled by anyone other than trained users having appropriate technical and mechanical expertise. The information and documentation contained in our catalog and on the website, [www.hydraforce.com](http://www.hydraforce.com), is provided for technical illustration purposes only and may not be used or relied upon as a statement of suitability for use in any particular application. Users, through their own analysis and testing, are solely responsible for making the final selection of HydraForce systems and components and for assuring that HydraForce products are used in a safe and intended manner with all performance, endurance, maintenance, safety and warning requirements necessary for safe application being met. Users are responsible for determining that HydraForce product data and specifications are suitable and sufficient for all intended applications and reasonably foreseeable uses of the components or systems. Each application is unique and prospective purchasers are responsible for conducting their own tests and studies to determine the fitness of HydraForce's products for their particular purposes and specific applications.

Since the use of the information contained in HydraForce product documentation, including this document, and the conditions under which HydraForce products are used are beyond the control of HydraForce, it is the obligation of each user of HydraForce products to carefully read and understand this document and all other documentation, instructions, and manuals supplied with HydraForce products and to determine the correct and safe methods of installation, inspection, testing, operation, and maintenance of HydraForce products, and the correct and safe conditions of use of HydraForce products and any systems into which they may be integrated by the user. In addition to the disclaimers and limitations of liability set forth below, in no event may HydraForce be held responsible for unsafe installation, inspection, testing, operation, and maintenance practices of users employing HydraForce products or for any property damage or personal injuries arising out of the use or handling of HydraForce products by anyone other than trained users having appropriate technical and mechanical expertise.

**DISCLAIMER OF WARRANTIES. USERS' USE OF HYDRAFORCE PRODUCTS IS AT THEIR SOLE RISK, EXCEPT FOR ANY EXPRESS LIMITED WARRANTY THAT MAY BE PROVIDED FOR SPECIFIC HYDRAFORCE PRODUCTS. HYDRAFORCE EXPRESSLY DISCLAIMS, TO THE MAXIMUM EXTENT PERMITTED BY APPLICABLE LAW, ALL WARRANTIES OR ANY KIND, WHETHER EXPRESS OR IMPLIED, INCLUDING BUT NOT LIMITED TO THE IMPLIED WARRANTIES OF MERCHANTABILITY, FITNESS FOR A PARTICULAR PURPOSE, OR ARISING BY STATUTE OR OTHERWISE IN LAW OR FROM A COURSE OF DEALING OR USAGE OF TRADE. NO ADVICE OR INFORMATION, WHETHER ORAL OR WRITTEN, OBTAINED BY YOU FROM HYDRAFORCE OR CONTAINED IN THIS DOCUMENT OR ANY OF THE HYDRAFORCE PRODUCT DOCUMENTATION, SHALL CREATE ANY WARRANTY.**

**LIMITATION OF LIABILITY. [OTHER THAN REMEDIES THAT ARE GRANTED UNDER ANY EXPRESS LIMITED WARRANTY THAT MAY BE PROVIDED FOR SPECIFIC HYDRAFORCE PRODUCTS,] HYDRAFORCE SHALL NOT BE LIABLE FOR, NOR SHALL YOU MAKE ANY CLAIM FOR (WHETHER BASED ON CONTRACT, TORT, PRODUCTS LIABILITY, STRICT OR STATUTORY LIABILITY, NEGLIGENCE OR OTHERWISE), ANY DIRECT, INDIRECT, INCIDENTAL, SPECIAL, CONSEQUENTIAL, PUNITIVE, OR EXEMPLARY DAMAGES (EVEN IF HYDRAFORCE HAS BEEN ADVISED OF THE POSSIBILITY OF SUCH DAMAGES) ARISING OUT OF USE OF HYDRAFORCE PRODUCTS, INCLUDING, BUT NOT LIMITED TO, DAMAGES FOR ECONOMIC LOSS OF PROFITS OR SAVINGS; LOST WAGES; DAMAGES TO OR LOSS OF USE OF PROPERTY; BODILY INJURY; MEDICAL PAYMENTS; PAIN AND SUFFERING; AND LOSS OF CONSORTIUM. IN THE EVENT THAT APPLICABLE LAW DOES NOT ALLOW THE EXCLUSION OF WARRANTIES STATED HEREIN OR THE LIMITATION OF LIABILITY STATED HEREIN, THEN YOU EXPRESSLY AGREE THAT IN NO EVENT WILL THE LIABILITY OF HYDRAFORCE, FOR ANY CLAIM OR DAMAGES HEREUNDER EXCEED THE PURCHASE PRICE PAID FOR THE HYDRAFORCE PRODUCT IN CONTROVERSY.**

HydraForce and the HydraForce logo are registered trademarks of HydraForce, Inc.  
The entire content of this catalog is copyright 2013 HydraForce, Inc.

## How to Use This Catalog

**Integr8** is a new concept in hydraulic controls from HydraForce. It takes the best combination of cartridge valves and integrates them into optimally designed manifolds for cylinder and motor control. INTEGR8 is the fastest way to arrive at efficient, reliable hydraulic control solutions.

Here's how to INTEGR8 your application:

- 1. Start with the function you need** - flow control or directional control, direct-acting or pilot-operated.
- 2. Choose the INTEGR8 component** for the function, using the Table of Contents in this catalog. If you are using i-Design to build your circuit, select the INTEGR8 component from the library menu, or visit [hydraforce.com/INTEGR8](http://hydraforce.com/INTEGR8) to download the base schematic.
- 3. Choose your flow rate** - each INTEGR8 solution is available in several flow rates and can be adjusted within a range for the application. Refer to the RATINGS section for parameters.
- 4. Fine-tune your circuit** by adjusting or adding cartridge valves, specifying seals, etc.

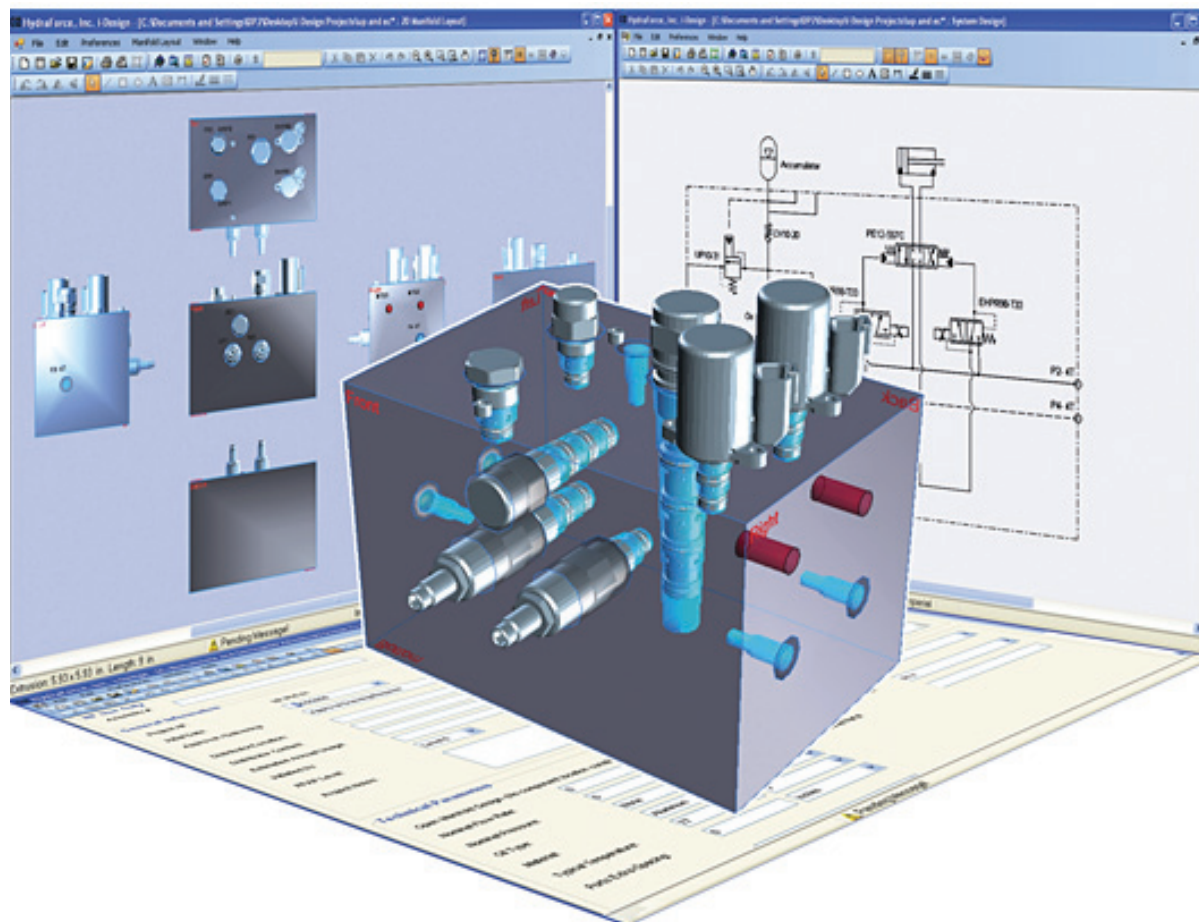
Specifying an INTEGR8 control solution gives you flexibility to choose the flow rate, pressure rating, and control parameters you need for an application.

Detailed specifications for the individual cartridge valves are provided in the **HydraForce Master Catalog**. You can always find the most current valve specifications and ratings online at [www.hydraforce.com](http://www.hydraforce.com).

To design your circuit, download free i-Design manifold design software at <http://info.hydraforce.com/downloadi-Design>

Manifold design assistance is also available by contacting HydraForce at <http://info.hydraforce.com/Free-Custom-Circuit-Consultation/>. A HydraForce distributor or sales representative will consult with you to provide application engineering assistance.

You can also email us at one of the following addresses:  
From the U.S. - [sales-us@hydraforce.com](mailto:sales-us@hydraforce.com)  
From U.K and Europe - [sales-uk@hydraforce.com](mailto:sales-uk@hydraforce.com)  
From Asia, Africa, Australia, Pacific - [sales-intl@hydraforce.com](mailto:sales-intl@hydraforce.com)





# INTEGR8 - Engineered Hydraulic Control Solutions

Here are 8 reasons to INTEGR8:

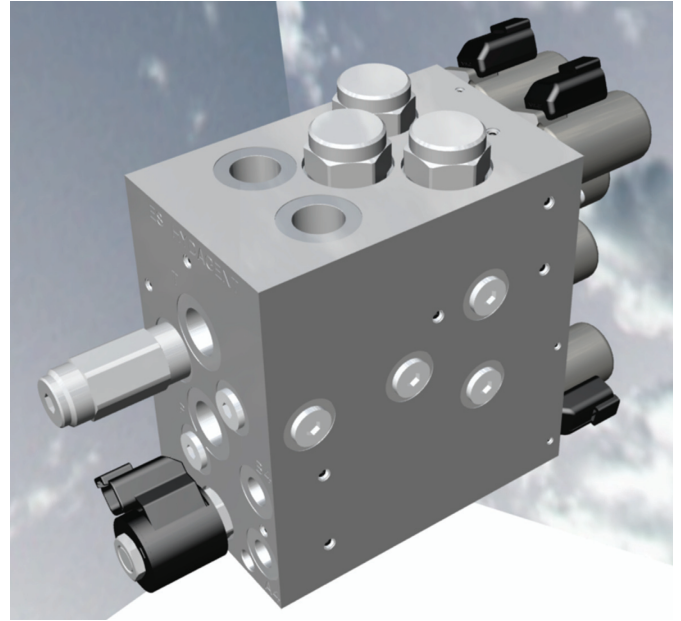
**1 Innovation** - Expand your creative options with the largest range of performance-optimized cartridge valves in the industry. Cartridge valve and manifold system technologies provide performance options and feature flexibility unsurpassed by alternative valve configurations.

**2 System Efficiency** - Cartridge valves can be combined and uniquely packaged to optimize machine efficiency, improve operator control, and integrate multiple functions into a common control scheme. Different-sized components can be inter-mixed to optimize metering characteristics, and minimize both size and cost. No need to oversize and compromise low flow functions in order to accommodate the highest flow function of the valve body. Each function is individually tailored.

**3 Serviceability** - Significantly reduce machine downtime and cost for repair or maintenance with a screw-in manifold valve solution that is easily, quickly and economically serviced.

**4 Custom Capabilities** - No fixed configuration castings. Manifold housings can be configured in a variety of sizes, shapes and materials to fit tight spaces. Port locations can be placed to improve hose routings, reduce installation time and minimize installed costs.

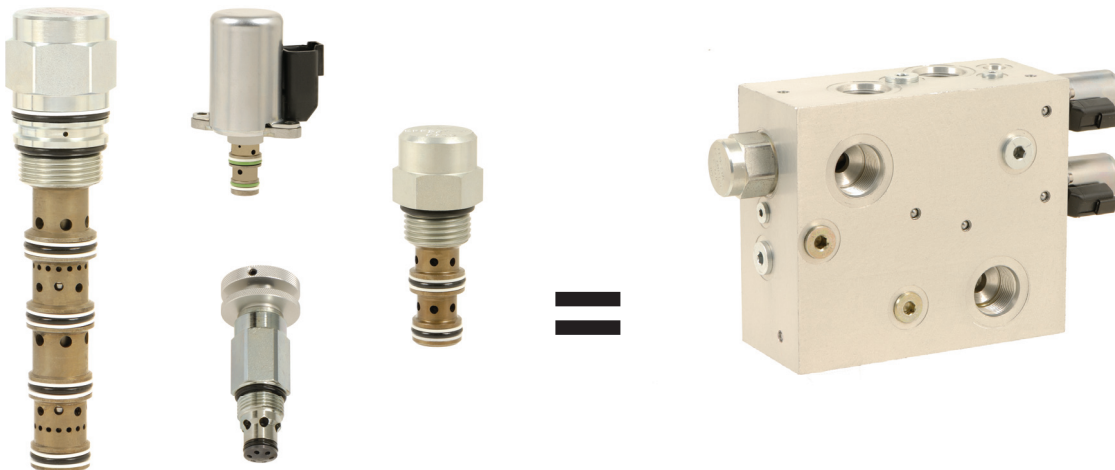
**5 Flexibility** - INTEGR8 components can be specified as tested, rated and performance detailed circuit configurations. Using these base configurations, systems can be customized with individual function control features, all within a machine specific, customer specified housing construction. Machine options can also be integrated allowing operating efficiency and vehicle performance to be maximized.



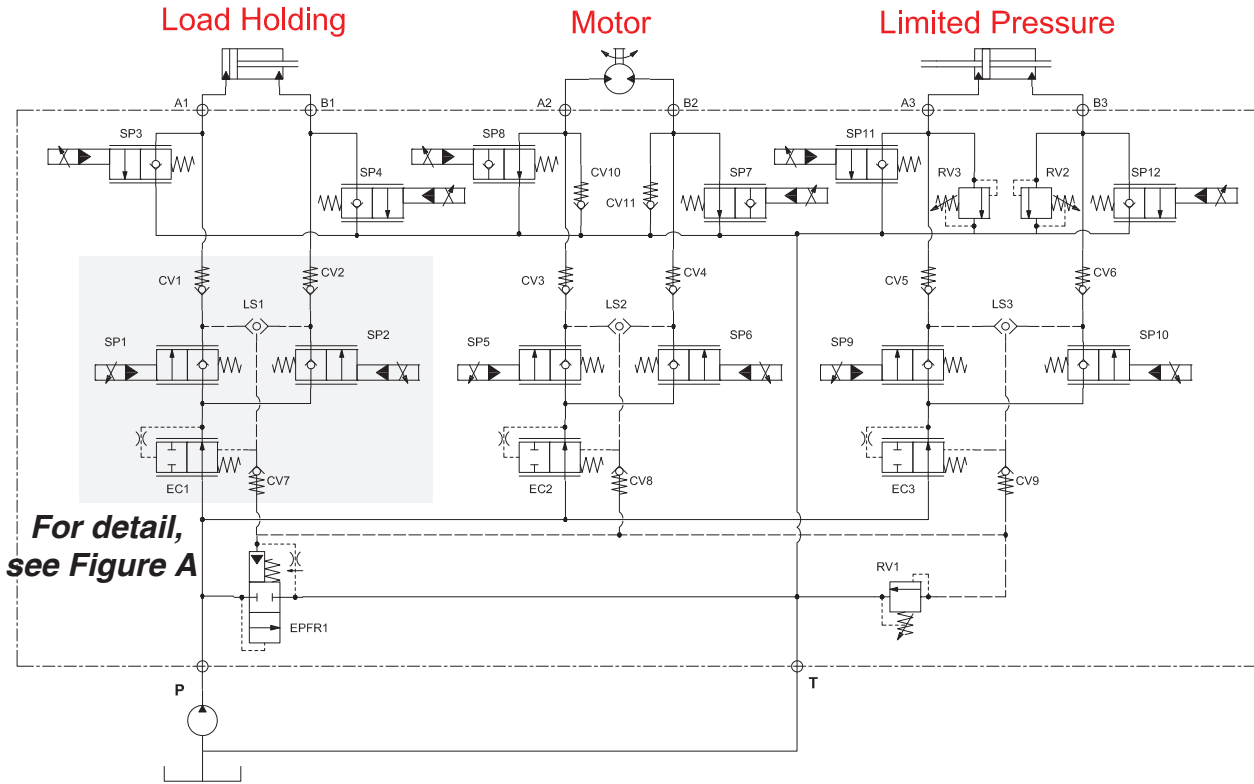
**6 Durability** - Proven quality and reliability in the most demanding applications. Every manifold is 100% function-tested at the factory, and every valve comes with the HydraForce five-year warranty.

**7 Optimal Performance** - Cartridge valves offer precise, application-coordinated performance and unmatched tune-ability. Performance can be designed to offer features such as flow-sharing compensation, pre-compensation, port pressure protection, etc. Load sensing and/or pump unloading systems are also available to accommodate either fixed or variable pump supply.

**8 Fewer Leak Points** - A single manifold block with fewer connections presents less opportunity for hydraulic leakage.



# Flow Control Circuits, Pressure Compensated, Direct-Acting



Direct-acting, flow control valves can be used for load-holding, motor control and pressure limiting circuits.

Direct-acting flow control circuits can be configured in a variety of ways to accomplish a full range of load-holding and motion control functions for hydraulically powered equipment. The hydraulic schematic above depicts several of the many possible ways you can build a circuit.

To ensure a high-level of efficiency and consistent flow control, a load-sense based circuit featuring the SPxx-20x cartridge valve provides pressure-compensated proportional flow control. In addition to the SPxx-20x flow control valve, this direct-acting flow control circuit includes a HCVxx-20 check valve and ECxx-32 pressure compensator.

***"A load-sense circuit featuring the SPxx-2x cartridge valve provides pressure-compensated proportional flow control."***

Direct-acting flow control circuits are available in the following nominally rated flow capacities (with compensation - see details in following pages)

- 10.6 to 22.7 lpm (2.8 to 6.0 gpm)
- 37.1 to 70.1 lpm (9.8 to 18.5 gpm)
- 55.0 to 106.0 lpm (14.5 to 28.0 gpm)

## CARTRIDGE VALVE and PORTING KEY

- |            |                    |
|------------|--------------------|
| 1 SPxx-20  | WP Work Port       |
| 2 ECxx-32  | P Inlet Port       |
| 3 HCVxx-20 | LS Load Sense Port |

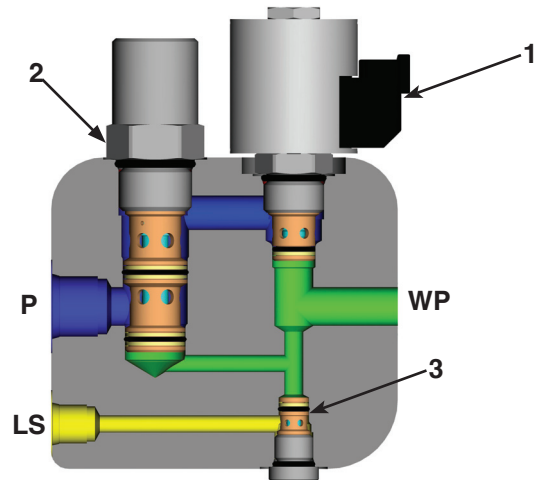


FIGURE A - DIRECT-ACTING FLOW CONTROL

# Theory of Operation - Direct-Acting Flow Control

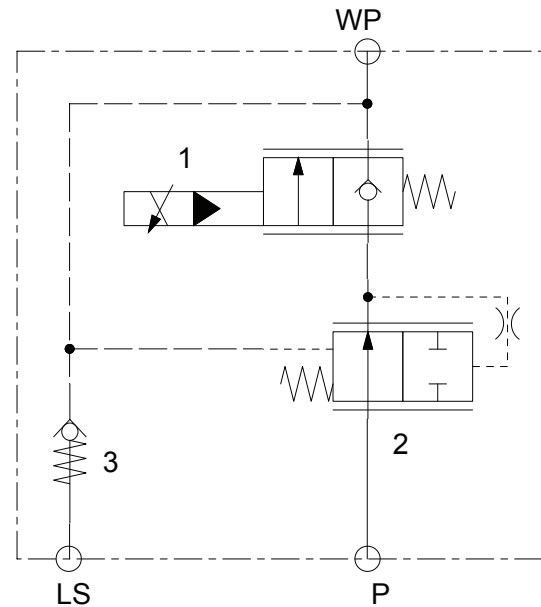
For simplicity, the load hold valve downstream of the work port (WP) has been omitted. In **Figure A - DIRECT-ACTING FLOW CONTROL**, all products are shown at rest and with no pressure applied to the inlet.

In **Figure B - DE-ENERGIZED**, the pump is on and system pressure is fed to the inlet of the flow control valve. The compensator closes to block the flow of oil to the SP flow control.

When the solenoid coil is energized (**Figure C - ENERGIZED**), oil is allowed to flow to the work port. The control pressure drop sensed across the flow control valve (SPxx-20x) will have increased to match the spring setting of the compensator (ECxx-32). The compensator spool opens and closes, balancing the supply pressure from the pump against the spring force plus load pressure to maintain consistent flow output. The compensator remains in this position as long as flow is commanded by the flow control valve. As command current to the coil is increased, this circuit not only provides precise metering and repeatable flow output, but flow output will be unaffected by changes in work port pressure.

The load pressure sensed by the compensator is also communicated across the check valve (HCVxx-20), and out the LS port to feed the rest of the main load sense circuit. The HCVxx-20 is a spring-biased check valve, and only allows load pressure to feed into the main load sense circuit; pressure from main load sense circuit is blocked. The main load sense circuit may be controlled using a by-pass compensator and fixed displacement pump, or feed directly into a variable displacement type pump.

## Schematic showing flow control



### CARTRIDGE VALVE and PORTING KEY

1	SPxx-20x	WP	Work Port
2	ECxx-32	LS	Load Sense Port
3	HCV06-20	P	Inlet Port

At the heart of this flow control circuit, the SPxx-2x valve is a two-way, poppet-type valve available in two configurations: normally closed (SPxx-20) and normally open (SPxx-21). SPxx-2x flow control valves are available in two metering configurations: Standard (Fine) Metering and Linear Metering models. Fine Metering models will have slightly lower maximum flow output due to lower area gain of poppet. See Performance Charts for metering characteristics.

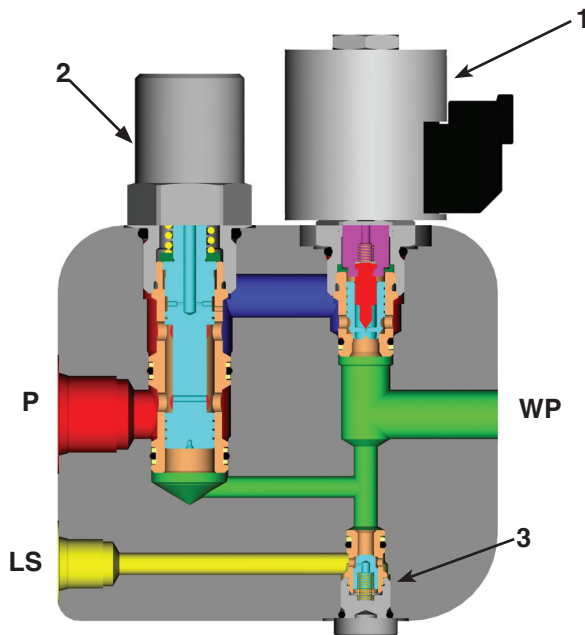


FIGURE B - DE-ENERGIZED

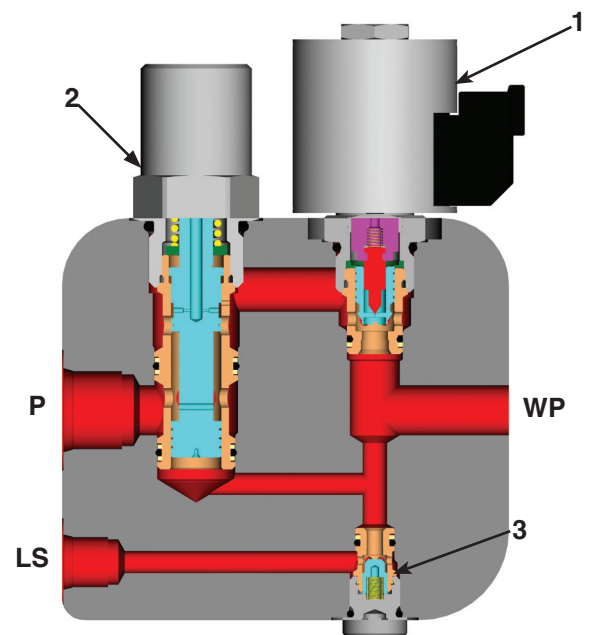
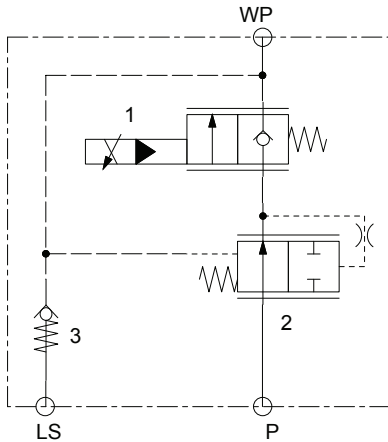


FIGURE C - ENERGIZED

# Direct-Acting, Pressure Compensated, Normally Closed



## CARTRIDGE VALVE and PORTING KEY

- |   |          |    |                 |
|---|----------|----|-----------------|
| 1 | SPxx-20x | WP | Work Port       |
| 2 | ECxx-32  | LS | Load Sense Port |
| 3 | HCV06-20 | P  | Inlet Port      |

## APPLICATION TIPS

Typical applications include conveyor drives, positioning of horizontal actuators such as swing or side shift, and control of lifting functions, i.e. boom, bucket, fork, etc. The following application tips should be taken into consideration:

- Use a closed loop current controller to ensure that constant current is delivered to the coil regardless of changes in resistance from temperature or voltage fluctuation. Refer to the Coil Operating Parameters chart on page 2.002.1 in the HydraForce Technical Catalog.
- Because SP valves have a variable orifice they are best applied when paired with a compensator to ensure consistent operation independent of any load-induced pressure.

## RATINGS

	SP08-20	SP08-20A	SP10-20	SP10-20A	SP12-20	SP12-20A
<b>Operating Pressure</b> bar/psi	207 bar/ 3000 psi	207 bar/ 3000 psi	241 bar/ 3500 psi	241 bar/ 3500 psi	241 bar/ 3500 psi	241 bar/ 3500 psi
<b>Flow Rating</b>	<b>80 psi spring</b> 10.6 lpm/2.8 gpm	<b>80 psi spring</b> 11.7 lpm/3.1 gpm	<b>80 psi spring</b> 40.6 lpm/10.7 gpm	<b>80 psi spring</b> 44.7 lpm/11.8 gpm	<b>80 psi spring</b> 55.0 lpm/14.5 gpm	<b>80 psi spring</b> 57.2 lpm/15.1 gpm
<b>Spring Size</b>	<b>150 psi spring</b> 14.8 lpm/3.9 gpm	<b>150 psi spring</b> 16.7 lpm/4.4 gpm	<b>160 psi spring</b> 55.7 lpm/14.7 gpm	<b>160 psi spring</b> 62.9 lpm/16.6 gpm	<b>160 psi spring</b> 72.4 lpm/19.1 gpm	<b>160 psi spring</b> 86.8 lpm/22.9 gpm
<b>Size</b> lpm/gpm	<b>250 psi spring</b> 19.7 lpm/5.2 gpm	<b>250 psi spring</b> 23.1 lpm/6.1 gpm	<b>220 psi spring</b> 62.2 lpm/16.4 gpm	<b>220 psi spring</b> 70.1 lpm/18.5 gpm	<b>200 psi spring</b> 76.2 lpm/20.1 gpm	<b>200 psi spring</b> 86.4 lpm/22.8 gpm

## DESCRIPTION

A combination of valves working together to provide optimal control of hydraulically powered functions. This direct-acting, pressure-compensated product controls flow proportionally in response to a change in current.

Valves in circuit include:

- **SPxx-20x** flow control valve
- **ECxx-32** pressure compensator
- **HCVxx-20** check valve

For applications requiring low work port leakage, the use of a pilot-operated check valve or counter balance valve is suggested.

## OPERATION

When coil is de-energized, all ports are blocked. When coil is energized, flow is allowed to the work port (WP). The control pressure drop sensed across the flow control valve (SPxx-20x) will have increased to match the spring setting of the compensator (ECxx-32), and closes to restrict supply flow from pump. The compensator spool balances the supply pressure from the pump against the spring force plus load pressure to maintain consistent flow output. The compensator remains in this position as long as flow is commanded by the flow control valve.

The load pressure sensed by the compensator is also communicated across the check valve (HCVxx-20), and out the LS port to feed the rest of the main load sense circuit. The main load sense circuit may be controlled using a by-pass compensator and fixed displacement pump, or feed directing into a variable displacement type pump.

The heart of this flow control circuit is the SPxx-20x valve, a two-way, poppet-type, normally closed valve. When de-energized, it acts as a check valve, blocking pump flow. When energized, the poppet lifts to allow pump flow out the active work port.

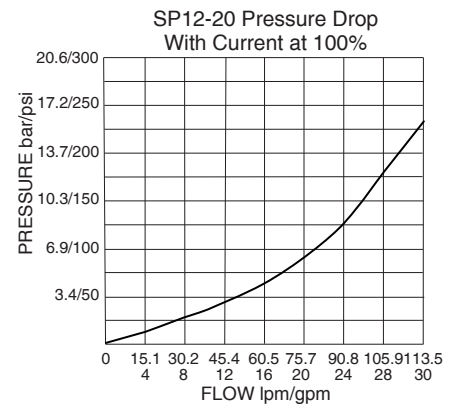
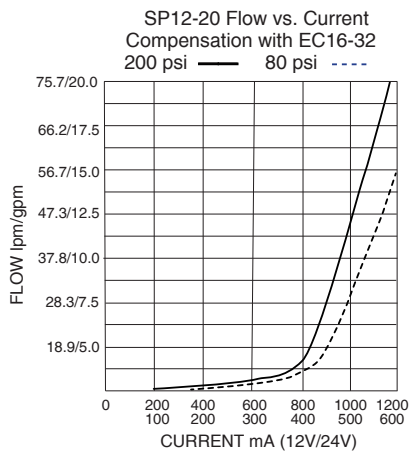
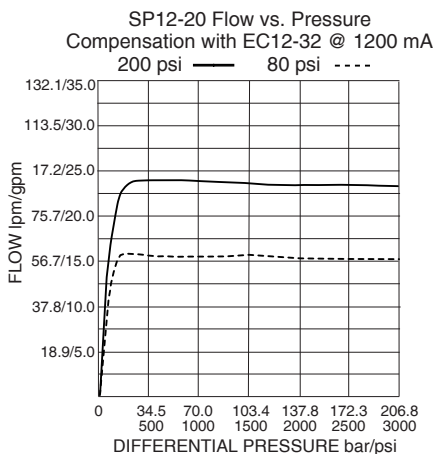
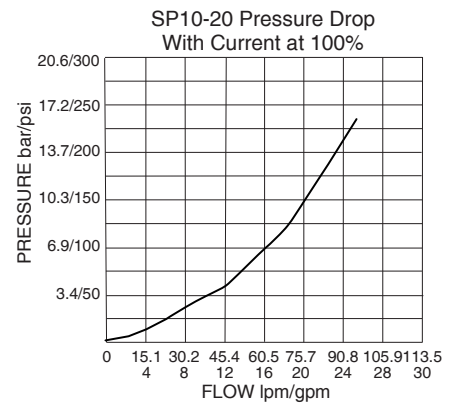
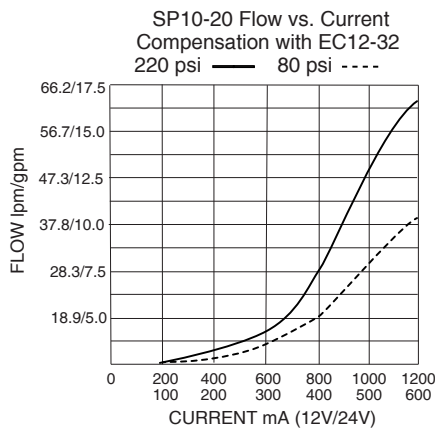
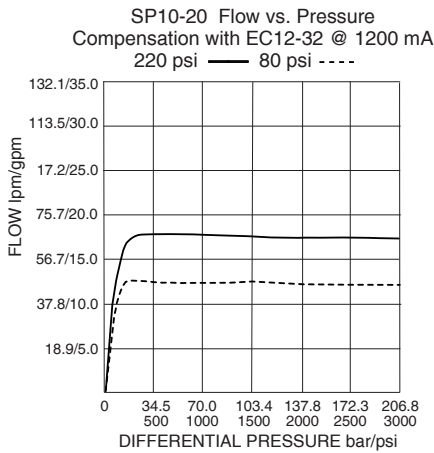
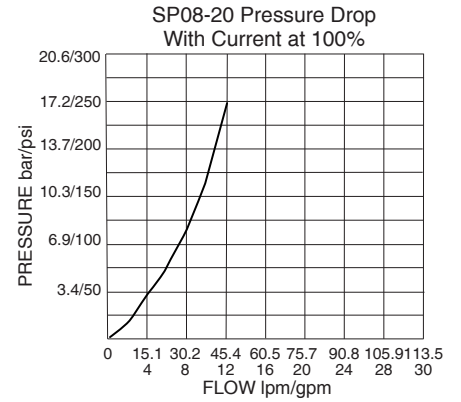
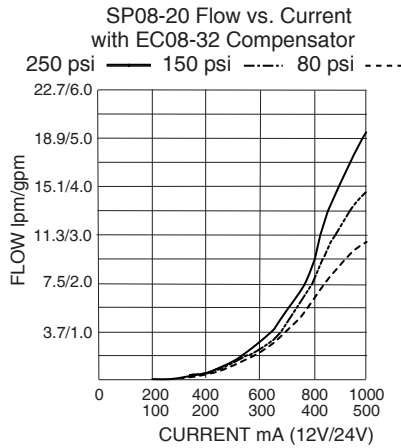
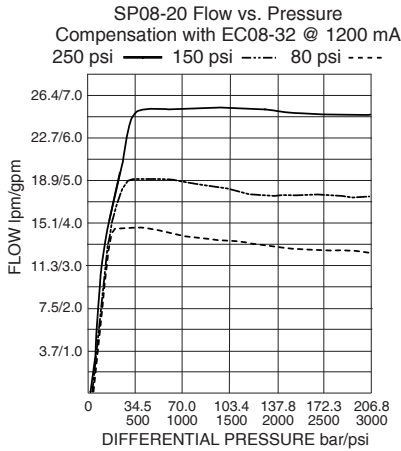
HCVxx-20 is a spring-biased check valve, and only allows load pressure to feed into the main load sense circuit; pressure from main load sense circuit is blocked.

## FEATURES

- Continuous duty unitized, molded coil or weathertight IP69-rated E-coil.
- Several compensation values available.
- Manual override and screen options.
- Cartridge technology allows for ease of servicing.
- Electronic controllers optimized for electro-hydraulic integration - visit <http://www.hydraforce.com/ElVeCon/EIVeCon.htm>
- Industry common cavities



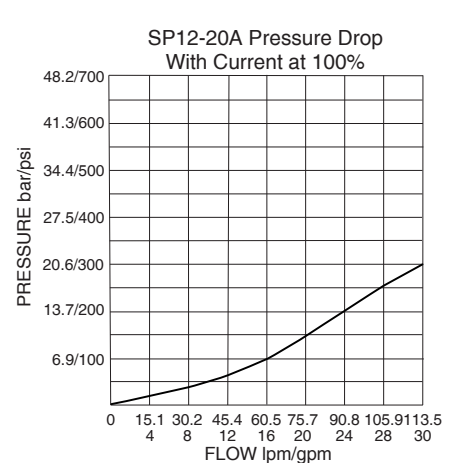
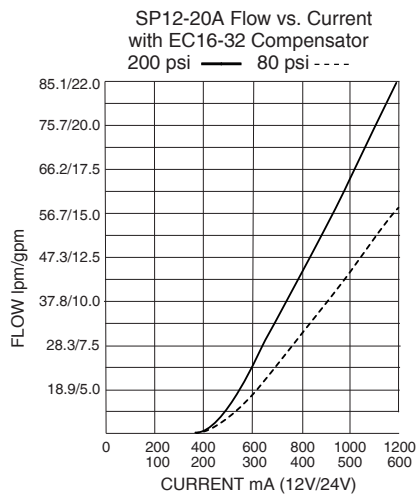
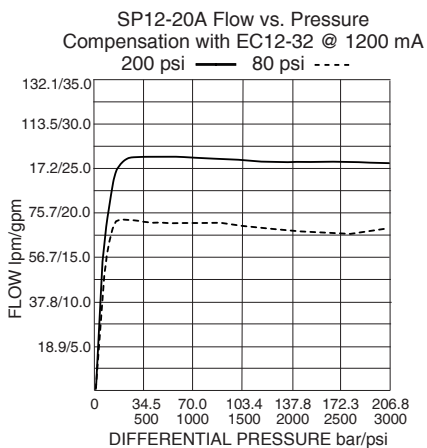
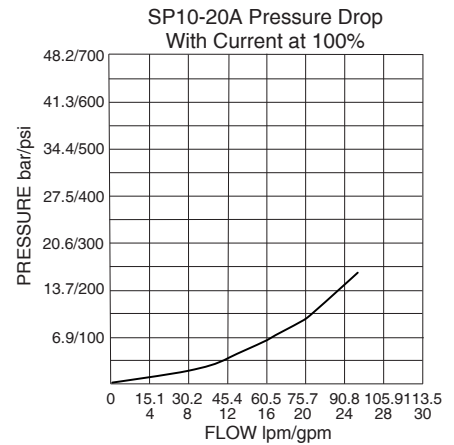
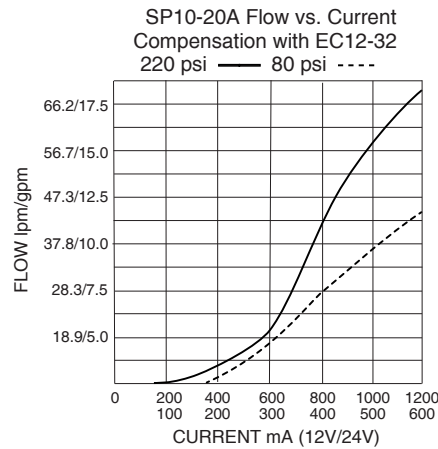
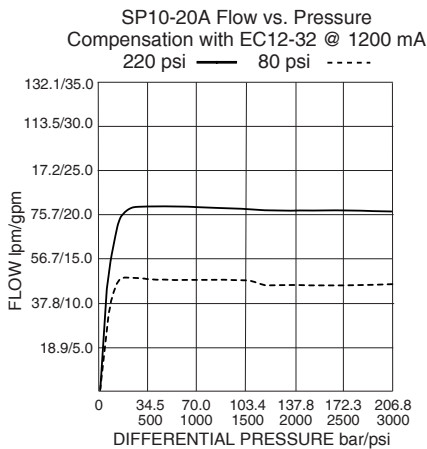
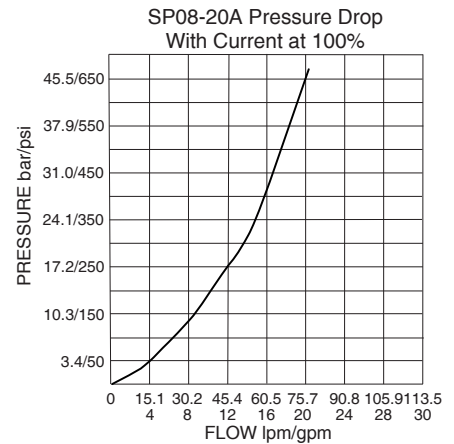
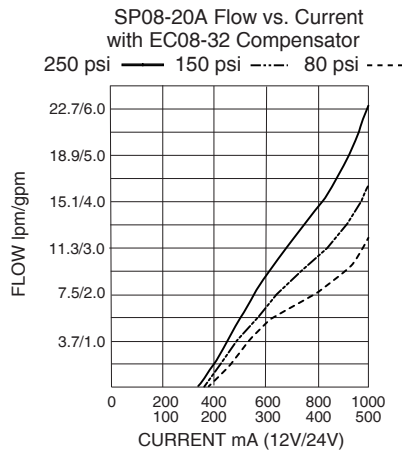
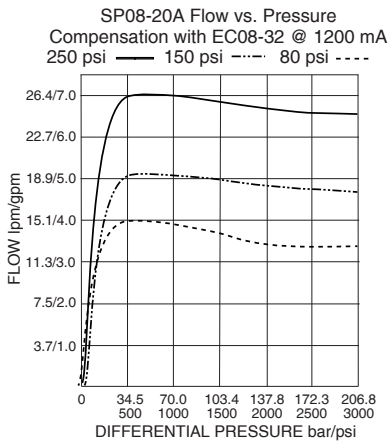
# Performance Charts - Standard Fine Metering SPxx-20



## Notes:

1. Flow charts for the SP10-xx and SP12-xx depict flow ratings with high and low spring selections. See Ratings table for flow rates with intermediate sized spring.
2. Pressure drop performance is based upon cavity machining and associated port connections machined in accordance with HydraForce cavity specifications. Pressure drop performance is subject to change based on actual manifold/circuit design.

# Performance Charts - Linear Metering Option SPxx-20A



**Notes:**

1. Flow charts for the SP10-xx and SP12-xx depict flow ratings with high and low spring selections. See Ratings table for flow rates with intermediate sized spring.
2. Pressure drop performance is based upon cavity machining and associated port connections machined in accordance with HydraForce cavity specifications. Pressure drop performance is subject to change based on actual manifold/circuit design.

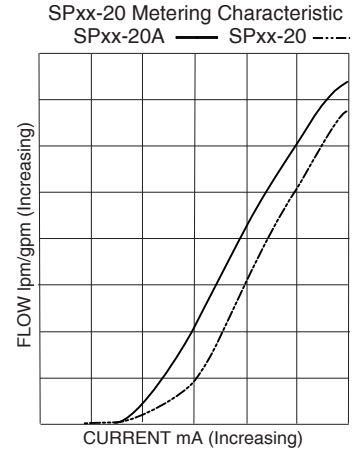
# Ordering Information - SPxx-20 and SPxx-20A

## Metering Options

HydraForce offers a choice of two metering options on its SPxx-20 cartridge valves. The standard metering option provides fine metering for smooth control. For applications that require extra flow capacity rather than fine metering, a linear metering option is available.

Flow vs. current performance for standard fine and linear metering is charted on the adjacent graph.

To specify the Linear Metering Option, add an "A" to the valve model code. See the To Order section.

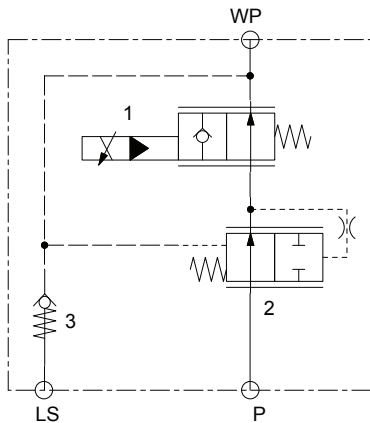


## TO ORDER

To order, refer to ordering information for the individual cartridge valves.

Flow Control Elements			Control Option
	1	2	3
Flow Rating	Electro-Proportional Flow Control Valve	Compensator	Check Valve
10.6 lpm (2.8 gpm)	SP08-20	EC08-32-0-N-80	HVC06-20-0-U-05
14.8 lpm (3.9 gpm)		EC08-32-0-N-150	
19.7 lpm (5.2 gpm)		EC08-32-0-N-250	
11.7 lpm (3.1 gpm)	SP08-20A	EC08-32-0-N-80	
16.7 lpm ( 4.4 gpm)		EC08-32-0-N-150	
23.1 lpm (6.1 gpm)		EC08-32-0-N-250	
40.6 lpm (10.7 gpm)	SP10-20	EC12-32-0-N-80	
55.7 lpm (14.7 gpm)		EC12-32-0-N-160	
62.2 lpm (16.4 gpm)		EC12-32-0-N-220	
44.7 lpm (11.8 gpm)	SP10-20A	EC12-32-0-N-80	
62.9 lpm (16.6 gpm)		EC12-32-0-N-160	
70.1 lpm (18.5 gpm)		EC12-32-0-N-220	
55.0 lpm (14.5 gpm)	SP12-20	EC16-32-0-N-80	
72.4 lpm/19.1 gpm		EC12-32-0-N-160	
76.2 lpm (20.1 gpm)		EC16-32-0-N-200	
57.2 lpm (15.1 gpm)	SP12-20A	EC16-32-0-N-80	
86.8 lpm/22.9 gpm		EC12-32-0-N-160	
86.4.0 lpm (23.3 gpm)		EC16-32-0-N-200	

# Direct-Acting, Pressure Compensated, Normally Open



## CARTRIDGE VALVE and PORTING KEY

- |   |          |    |                 |
|---|----------|----|-----------------|
| 1 | SPxx-21x | WP | Work Port       |
| 2 | ECxx-32  | LS | Load Sense Port |
| 3 | HCV06-20 | P  | Inlet Port      |

## APPLICATION TIPS

Typical applications include conveyor drives, positioning of horizontal actuators such as swing or side shift, and control of lifting functions, i.e. boom, bucket, fork, etc.

The following application tips should be taken into consideration:

- Use a closed loop current controller to ensure that constant current is delivered to the coil regardless of changes in resistance from temperature or voltage fluctuation. Refer to the Coil Operating Parameters chart on page 2.002.1 in the HydraForce Technical Catalog.
- Because SP valves have a variable orifice they are best applied when paired with a compensator to ensure consistent operation independent of any load-induced pressure.

## DESCRIPTION

A combination of valves working together to provide optimal control of hydraulically powered functions. This direct-acting, pressure-compensated product controls flow proportionally in response to a change in current.

Valves in circuit include:

- **SPxx-21x** flow control valve
- **ECxx-32** pressure compensator
- **HCVxx-20** check valve

For applications requiring low work port leakage, the use of a pilot-operated check valve or counter balance valve is suggested.

## OPERATION

When coil is de-energized, flow is allowed to the work port (WP). When energized, flow is blocked. The control pressure drop sensed across the flow control valve (SPxx-21x) will have increased to match the spring setting of the compensator (ECxx-32), and closes to restrict supply flow from pump. The compensator spool balances the supply pressure from the pump against the spring force plus load pressure to maintain consistent flow output. The compensator remains in this position as long as flow is commanded by flow control valve.

The load pressure sensed by the compensator is also communicated across the check valve (HCVxx-20), and out the LS port to feed the rest of the main load sense circuit. The main load sense circuit may be controlled using a by-pass compensator and fixed displacement pump, or feed directing into a variable displacement type pump.

The heart of this flow control circuit is the SPxx-21x valve, a two-way, poppet-type, normally open valve. When de-energized, it allows flow from the work port. When energized, the poppet closes to block flow from the work port.

HCVxx-20 is a spring-biased check valve, and only allows load pressure to feed into the main load sense circuit; pressure from main load sense circuit is blocked.

## FEATURES

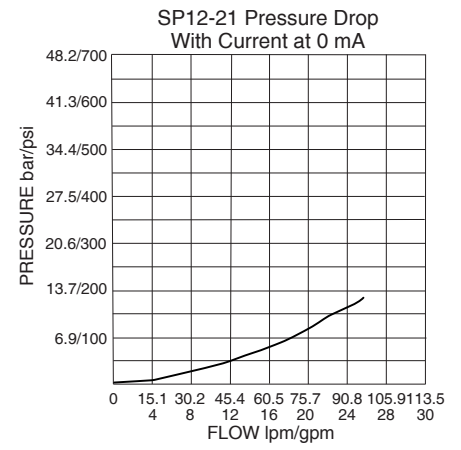
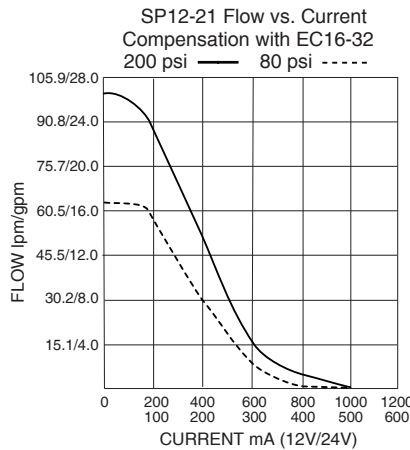
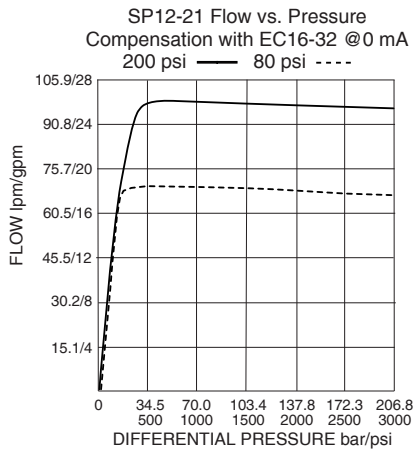
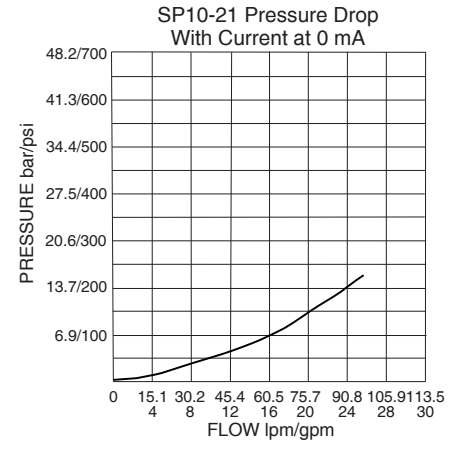
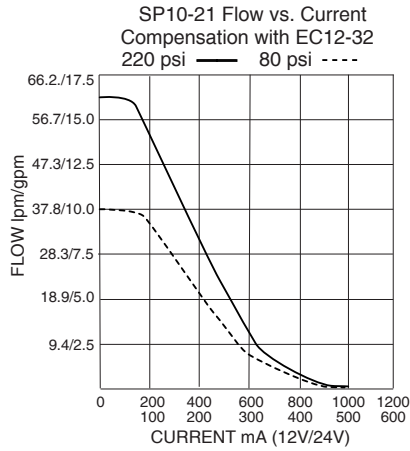
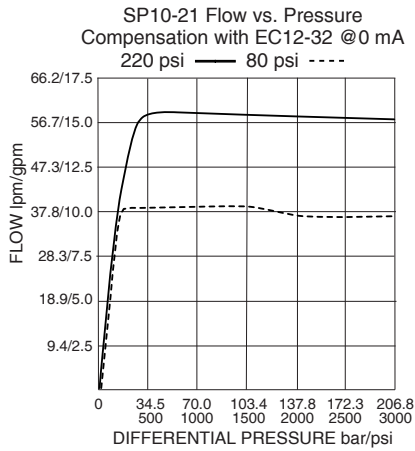
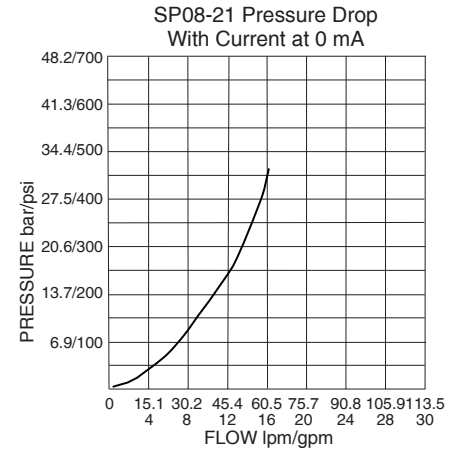
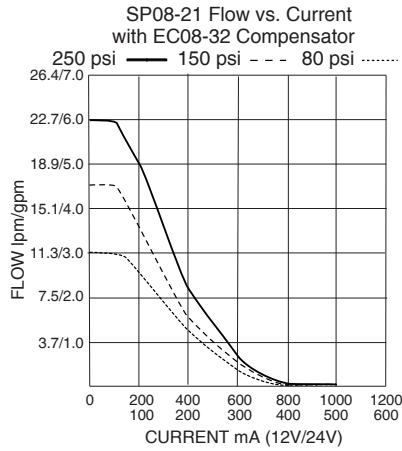
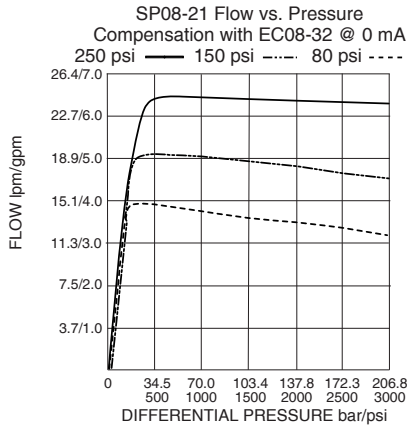
- Continuous duty unitized, molded coil or weathertight IP69-rated E-coil.
- Several compensation values available.
- Manual override and screen options.
- Cartridge technology allows for ease of servicing.
- Electronic controllers optimized for electro-hydraulic integration - visit <http://www.hydraforce.com/ElVeCon/EIVeCon.htm>
- Industry common cavities

## RATINGS

	SP08-21	SP10-21	SP10-21A	SP12-21	SP12-21A
<b>Operating Pressure</b> bar/psi	207 bar/ 3000 psi	241 bar/ 3500 psi	241 bar/ 3500 psi	241 bar/ 3500 psi	241 bar/ 3500 psi
<b>Flow Rating</b> <b>Spring Size</b> lpm/gpm	<b>80 psi spring</b> 11.7 lpm/3.1 gpm <b>150 psi spring</b> 17.0 lpm/4.5 gpm <b>250 psi spring</b> 22.7 lpm/6.0 gpm	<b>80 psi spring</b> 37.1 lpm/9.8 gpm <b>160 psi spring</b> 53.4 lpm/14.1 gpm <b>220 psi spring</b> 60.3 lpm/15.9 gpm	<b>80 psi spring</b> 39.8 lpm/10.5 gpm <b>160 psi spring</b> 58.4 lpm/15.4 gpm <b>220 psi spring</b> 65.6 lpm/17.3 gpm	<b>80 psi spring</b> 62.9 lpm/16.6 gpm <b>160 psi spring</b> 88.7 lpm/23.4 gpm <b>200 psi spring</b> 98.5 lpm/26.0 gpm	<b>80 psi spring</b> 71.3 lpm/18.8 gpm <b>160 psi spring</b> 95.5 lpm/28 gpm <b>200 psi spring</b> 106.0 lpm/28.0 gpm



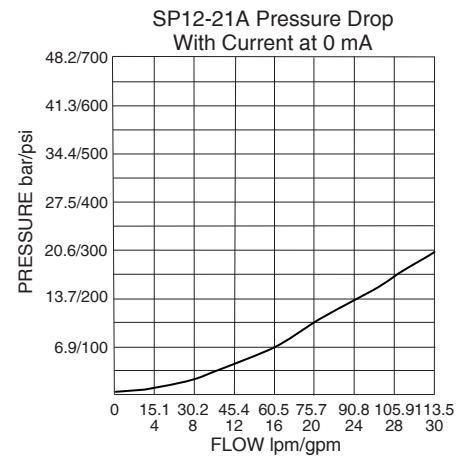
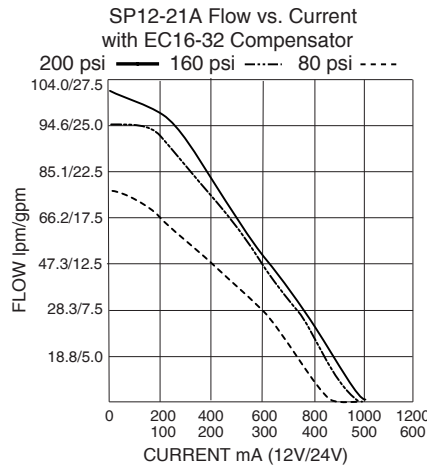
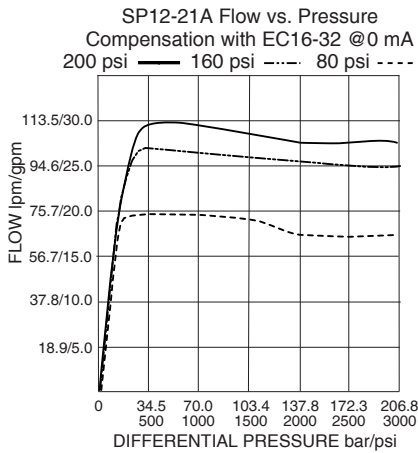
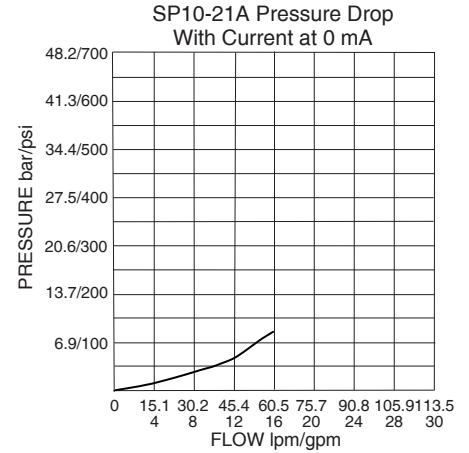
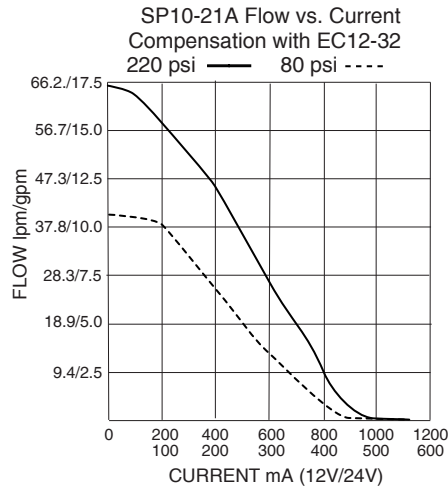
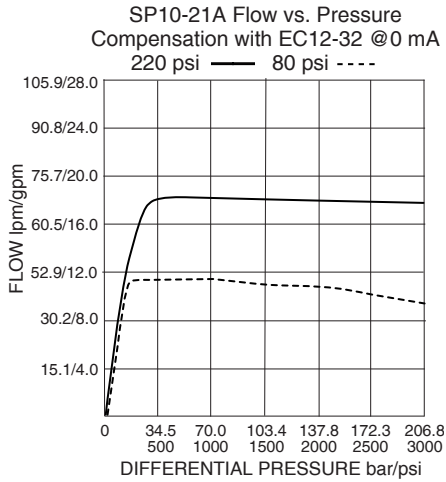
# Performance Charts - Standard Fine Metering SPxx-21



**Notes:**

- Flow charts for the SP10-xx and SP12-xx depict flow ratings with high and low spring selections. See Ratings table for flow rates with intermediate sized spring.
- Pressure drop performance is based upon cavity machining and associated port connections machined in accordance with HydraForce cavity specifications. Pressure drop performance is subject to change based on actual manifold/circuit design.

# Performance Charts - Linear Metering SPxx-21A



## Notes:

1. Flow charts for the SP10-xx and SP12-xx depict flow ratings with high and low spring selections. See Ratings table for flow rates with intermediate sized spring.
2. Pressure drop performance is based upon cavity machining and associated port connections machined in accordance with HydraForce cavity specifications. Pressure drop performance is subject to change based on actual manifold/circuit design.

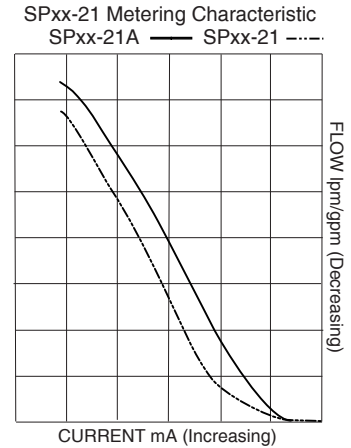
# Ordering Information - SPxx-21

## Metering Options

HydraForce offers a choice of two metering options on its SPxx-21 cartridge valves. The standard metering option provides fine metering for smooth control. For applications that require extra flow capacity rather than fine metering, a linear metering option is available.

Flow vs. current performance for standard fine and linear metering is charted on the adjacent graph.

To specify the Linear Metering Option, add an "A" to the valve model code. See the To Order section.

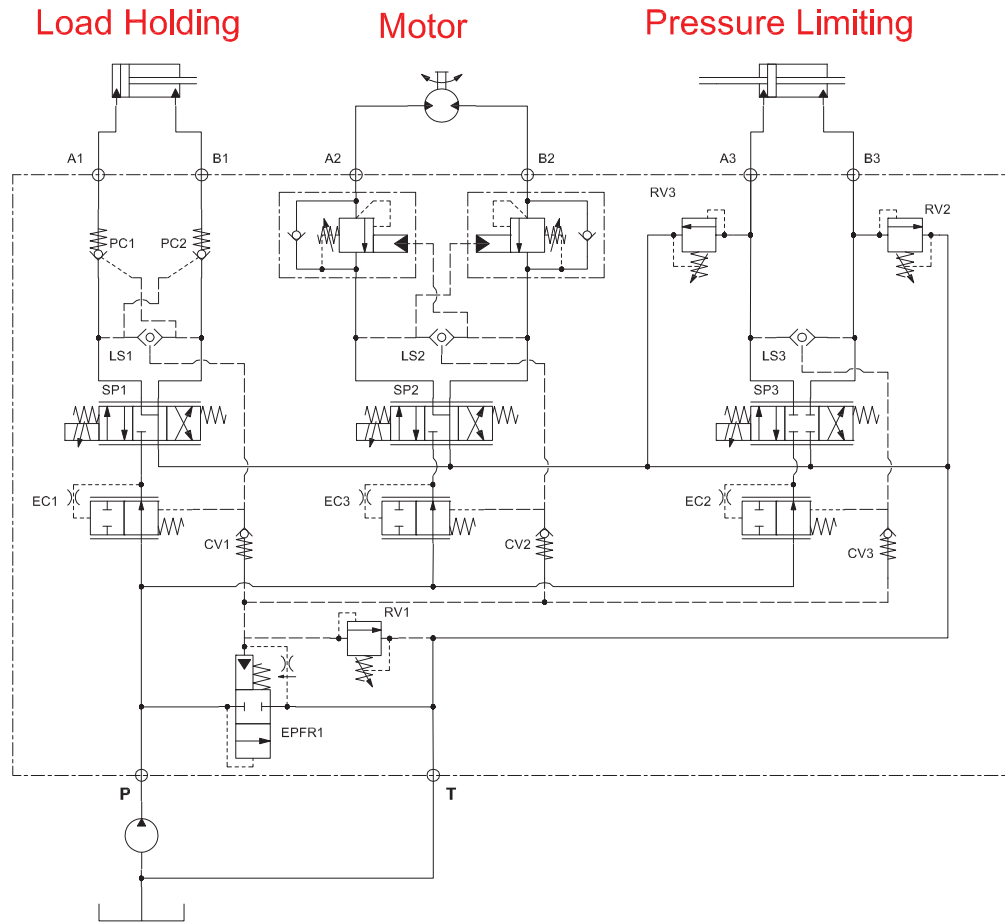


## TO ORDER

To order, refer to ordering information for the individual cartridge valves.

Flow Control Elements			
	1	2	3
Flow Rating	Electro-Proportional Flow Control Valve	Compensator	Check Valve
11.7 lpm (3.1 gpm)	SP08-21	EC08-32-0-N-80	HVC06-20-0-U-05
17.1 lpm (4.5 gpm)		EC08-32-0-N-150	
22.7 lpm (6.0 gpm)		EC08-32-0-N-250	
37.1 lpm (9.8 gpm)	SP10-21	EC12-32-0-N-80	
53.4 lpm/14.1 gpm		EC12-32-0-N-160	
60.3 lpm (15.9 gpm)		EC12-32-0-N-220	
39.8 lpm (10.5 gpm)	SP10-21A	EC12-32-0-N-80	
58.4 lpm/15.4 gpm		EC12-32-0-N-160	
65.6 lpm (17.3 gpm)		EC12-32-0-N-220	
62.9 lpm (16.6 gpm)	SP12-21	EC16-32-0-N-80	
88.7 lpm/23.4 gpm		EC16-32-0-N-160	
98.5 lpm (26.0 gpm)		EC16-32-0-N-200	
71.3 lpm (18.8 gpm)	SP12-21A	EC16-32-0-N-80	
95.5 lpm/28 gpm		EC16-32-0-N-160	
106.0 lpm (28.0 gpm)		EC16-32-0-N-200	

# Directional Control Valves - Getting Started



**Direct-acting directional control valves can be used for several machine functions.**

It is well-understood that efficiency is paramount and machine developers are always seeking ways to make machines operate faster or move a greater load while decreasing the output of the prime mover.

The backbone of a highly efficient hydraulic system is the load sense network. Load-sensing supports and sustains the delivery of pressurized hydraulic fluid throughout the system. It is interconnected with all of the other hydraulic components - the pumps, motors, accumulators and hydraulic valves. The load sense network depends on hydraulic control valves to regulate the demand of flow to each function. When developing your circuit, start with the basics of the load-sensing system.

## A Simple Load Sense System

Shown in the illustration above is a load sense system with a simple, inexpensive gear pump and unique HydraForce components, such as the SPxx-47x electro-proportional control valve.

Initially, when a load sense system is activated and the operator has **not** selected a function, all flow from the pump is diverted to tank through the EPFR bypass compensator.

This is advantageous from an efficiency standpoint, because the energy consumed is only that related to the flow from the pump and the bias spring value of the EPFR flow regulator.



## Load-Sense System Basics

For example, as current is applied to one of the coils of SP1, oil flows through EC1, SP1 and finally out through the work ports of either A1 or B1. As the actuator at A1 moves it imposes a load on the hydraulic system. This load pressure is transmitted through the load sense port of SP1 and further passed on to the function compensator. Ultimately, the load pressure is conveyed across the load sense network across the load sense check valves (CV1 through CV3) to the main load sense line.

### Selecting Multiple Functions

When multiple functions are operated simultaneously, only the highest load sense signal is allowed to pass to the main line through one of these check valves. As the operator demands a greater speed from the actuators (pressure doesn't necessarily increase as function flow increases) and/or if the load pressure increases because of resistance, the load sense pressure increases. The EPFR1 opens or closes in response to a change in the load pressure.

This changes the restriction in the pump to tank passage so that less or more flow is available in the hydraulic control circuit. Finally, the maximum pressure which the system can develop is regulated by the setting of the relief valve, RV1.

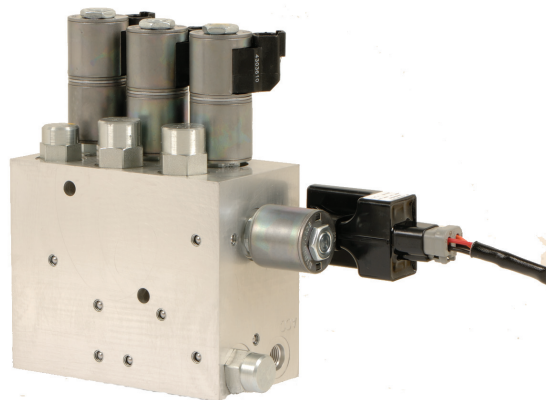
### Three Functions in Operation

One typical operating scenario could be that all three functions are running simultaneously. Assume that the resistance from the load between A2 and B2 is the greatest. The load pressure is transmitted through CV2. This pressure acts on EPFR1 and it closes in response to this pressure. The system pressure increases by the pressure required to move the load at port A2 or B2 plus the spring value of EPFR1. As the load pressure requirement increases eventually EPFR1 will close completely and all flow will be available to move the

actuators up until the point that the pressure equals that of the setting of RV1. Then flow will begin to exhaust across RV1. This system pressure is applied at the inlet of all three work functions. The individual function compensator valves (EC1, EC2 and EC3) will limit this pressure to each function to ensure consistent differential pressure across each SP valve. Thus, the speed at each actuator is controlled based on the opening of the orifice of the spool at the given work function and is not a function of the inlet pressure.

### Cartridge Valves Are The Building Blocks

Apart from the clear efficiency advantages of a properly designed load sense system, a HydraForce circuit will take full advantage of customizing for each individual application. Cartridge valves, which are the building blocks of the hydraulic world, can be arranged and installed into a custom manifold, eliminating the necessity to connect individual valves externally. Further, the correct size cartridge relative to the flow demand can be selected for each actuator. Therefore, the cost and size of the valve assembly is decreased while improving performance.



# Theory of Operation - Direct-Acting Directional Control

Shown below is a schematic of a typical directional control circuit, consisting of an SPxx-47C with an ECxx-32 and HLSxx-30 in combination to form the basis of a closed center, internally compensated load sensing directional control valve rated between 3 to 6 gpm (11 to 22 lpm) and 3500 psi (250 bar).

***"A typical directional control circuit featuring the SPxx-4x cartridge valve that provides a pressure-compensated, load-sensing directional control valve."***

The HCV06-20 completes the circuit when it is in use with multiple parallel functions. The directional valve has two solenoids, S1 and S2. When the S1 coil is energized, flow is allowed to Work Port B. When S2 is energized, flow is allowed to Work Port A.

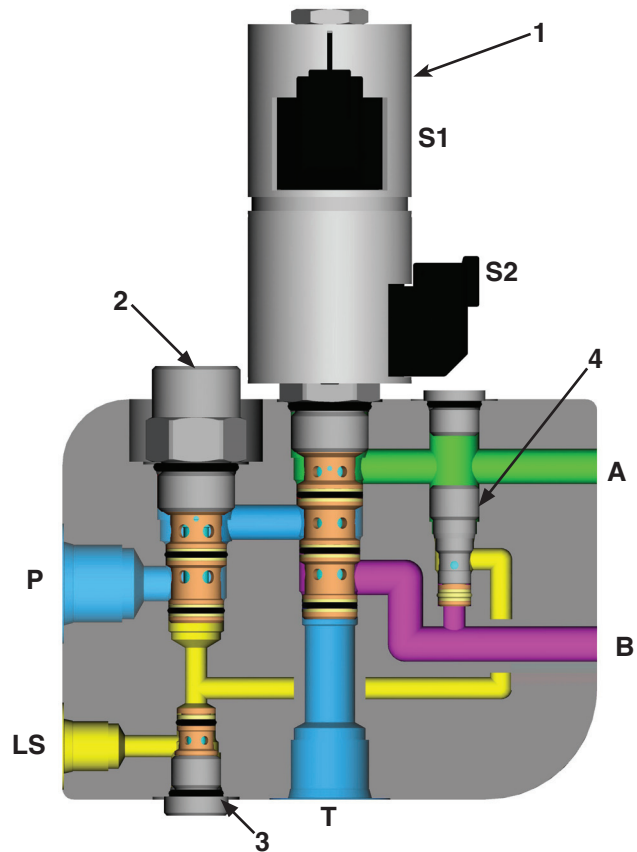
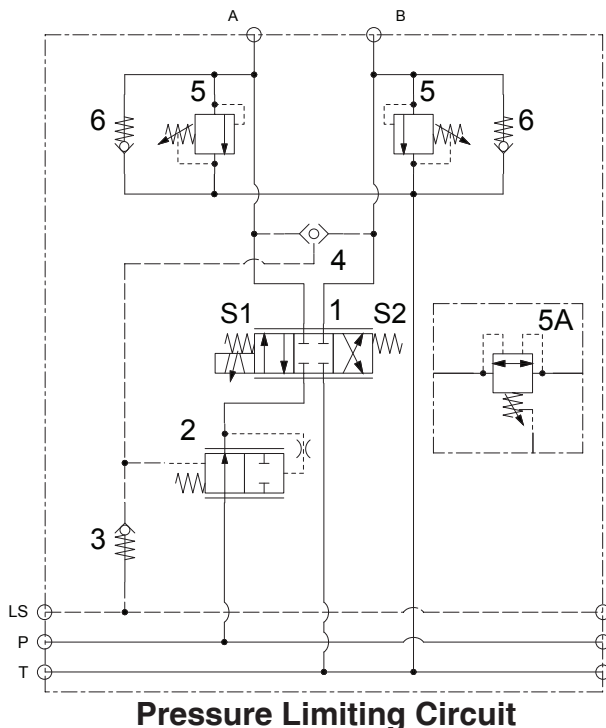
Note that unlike the schematic shown in the "Load Sense Basics" section, no load-holding valves are shown. These could be counterbalance valves or pilot operated check valves depending on the type of function being controlled as well as the neutral position of the directional control spool. Also, the relief valve and anti-cavitation protection check valves have been omitted. Only the essential valves of the circuit are identified.

In **Figure A**, the pump is off and no pressure is fed to the directional control.

## CARTRIDGE VALVE and PORTING KEY

1 SPxx-47C	A Work Port A
2 ECxx-32	B Work Port B
3 HCV06-20	LS Load Sense Port
4 HLS06-30	P Inlet Port
S1 Solenoid 1	T Tank
S2 Solenoid 2	

## Schematic showing directional control for double-acting actuator control



**FIGURE A - Direct-acting, spool-type pressure-compensated directional control**

# Theory of Operation - Direct-Acting Directional Control

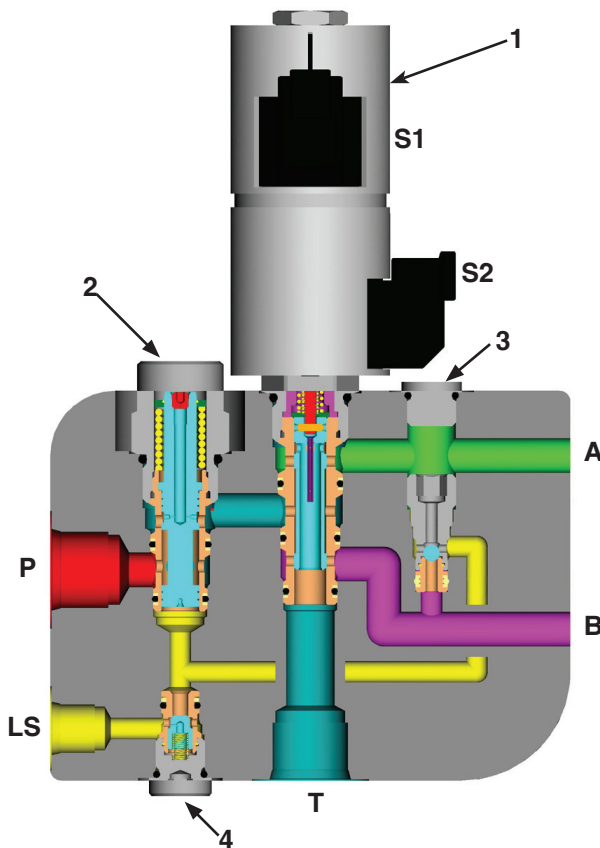
In **Figure B**, the pump is on and system pressure is fed to the inlet of the directional control compensator. Since no current is applied to S1 and S2, the compensator closes and blocks the flow of oil to the SPxx-47C.

**Figure C** depicts what occurs when the S1 coil is energized and the pump is on. The main spool of the directional control opens to allow oil to flow to Work Port B. At the same time oil is fed to the load sense network. The oil pushes the ball of the HLS06-30 load sense shuttle into a secondary position.

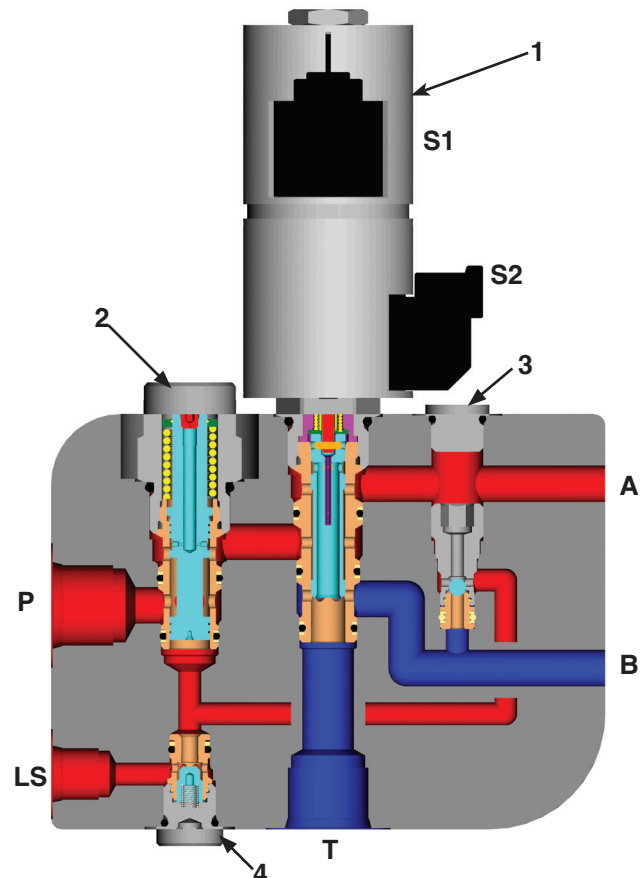
The oil also biases the compensator into an open position. The pressure demand at the load plus the spring force acting on the compensator spool balances the inlet pressure. The compensator moves in response to a change in load or system pressure, thereby regulating the pressure drop across the main directional spool.

As long as the hydraulic cylinder or motor demands flow, the compensator is in equilibrium. However, when the load or inlet pressure suddenly changes, the compensator responds accordingly. In other words, flow through the directional control is determined by the difference between load pressure induced at the actuator in the system and the main system pressure in combination with the restriction of the directional control valve (SPxx-47C working with the ECxx-32).

As long as the actuator at Port A and B is moving (flow is required) the compensator will remain in an open equilibrium position. Oil also flows out of the load sense check valve that feeds the main load sense element. This main load sense element may be a valve that is external to the pump or it may be internal to the pump



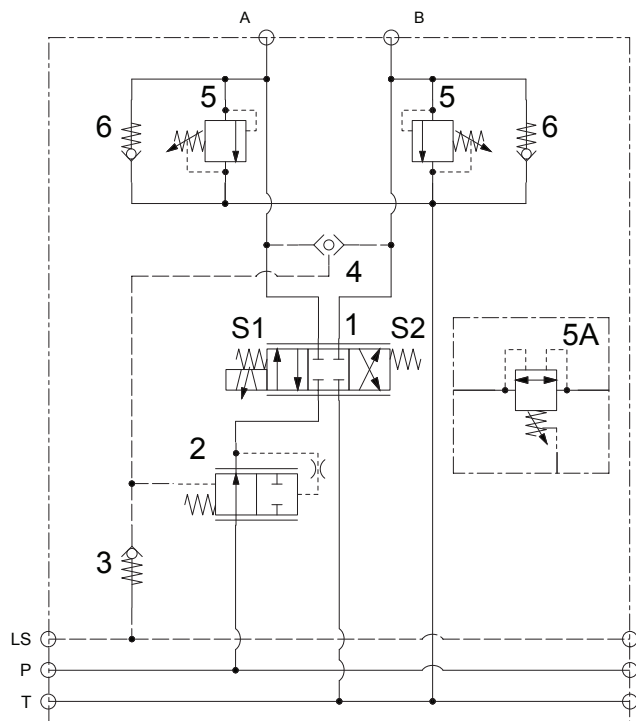
**FIGURE B** - Shown with pump on, coils de-energized and no flow post-compensated. The ECxx-32 pressure compensator regulates pressure of the hydraulic fluid.



**FIGURE C** - Shown energized, when the S1 coil of the SPxx-47C is energized, it works together with the other three valves in a hydraulic manifold circuit.

# Direct-Acting Cylinder Circuits

## SCHEMATIC



### CARTRIDGE VALVE and PORTING KEY

1	SPxx-47C	5a	CR10-28	A	Work Port A
2	ECxx-32	6	CV08-20	B	Work Port B
3	HCV06-20			LS	Load Sense Port
4	HLS06-30			P	Inlet Port
5	RV08-20			T	Tank

## APPLICATION TIPS

- The **SPxx-47C** has all ports blocked when the spool is in neutral. During transition, the spool starts metering symmetrically in all directions, controlling flow to and from the load.
- For cylinder applications it is recommended that the base end of the cylinder be connected to work port B.
- SP Series valves are not to be used as the primary load-holding valve. If load-holding is required, then either a counterbalance valve or dual-pilot-operated check valve must be used.
- When possible, the **SPxx-47C** valve should be mounted below the reservoir oil level. This will maintain oil in the armature preventing trapped air instability. If this is not feasible, mount the valve horizontally or install a check valve at the outlet of the manifold to prevent the introduction of air. See page 9.020.1 in the HydraForce Technical Catalog.
- Use a closed loop current controller to ensure that constant current is delivered to the coil regardless of changes in resistance from temperature or voltage fluctuation. Refer to the Coil Operating Parameters chart on page 2.002.1 in the HydraForce Technical Catalog.
- Optimal control signal 100 Hz PWM at maximum dither level
- Electronic controllers optimized for electro-hydraulic integration - visit <http://www.hydraforce.com/ElVeCon/ElVeCon.htm>

## DESCRIPTION

A combination of valves working together to control a double-acting cylinder. This direct-acting spool-type product controls flow proportionally in response to a change in current. The neutral position of the spool blocks oil at all ports. Valves in this circuit include: **SPxx-47C**, **ECxx-32**, **HLS06-B30**, **RV08-20**, **HCV06-20**, **CV08-20** and an optional **CR10-28**. For applications requiring low work port leakage, the use of a pilot-operated check valve or counter balance valve is suggested.

## OPERATION

When de-energized, work ports A and B are blocked. With power applied to either S1 or S2, flow is allowed to pass from P to either work port depending which coil is powered. The **ECxx-32** assures constant pressure drop across the metering spool. This assures consistent work port flow regardless of inlet or load conditions. Features include:

- Port reliefs to limit maximum work port pressure or protect the actuator against sudden shock load (**RV08-20**)
- A single valve cross port relief can be used as an alternative to replace two individual work port relief valves between the work ports. (**CR10-28**)
- Anti-cavitation check valves to ensure the cylinder remains filled with oil. (**CV08-20**)
- Load sense checks valves can be used to allow multiple work sections to be connected in parallel (**HCV06-20**)

## FEATURES

- Ideal for double-acting cylinder applications.
- Continuous duty unitized, molded coil or weather tight IP69- rated E-coil
- Hardened parts for long life.
- Cartridges are voltage interchangeable and easy to service
- Efficient wet-armature construction.
- Choice of compensation values
- Industry-common cavities

## RATINGS

	SP08-47C	SP10-47C
<b>Operating Pressure</b> bar/psi	241 bar/3500 psi	
<b>Flow Rating</b> <b>Spring Size</b> lpm/gpm	<b>150 psi spring</b> 11.4 lpm/3.0 gpm	<b>80 psi spring</b> 15.5 lpm/4.1 gpm <b>150 psi spring</b> 19.7 lpm/5.2 gpm <b>250 psi spring</b> 21.6 lpm/5.7 gpm

**Hysteresis:** Less than 7%

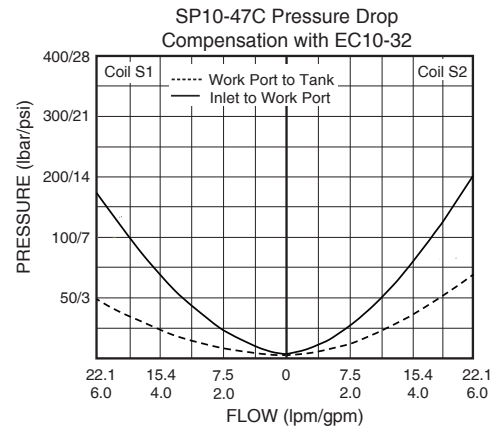
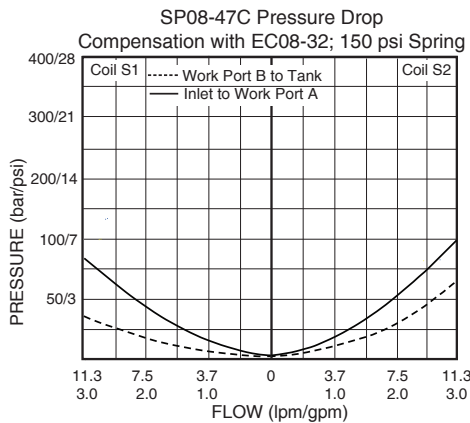
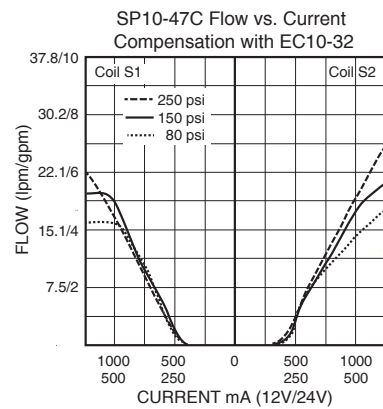
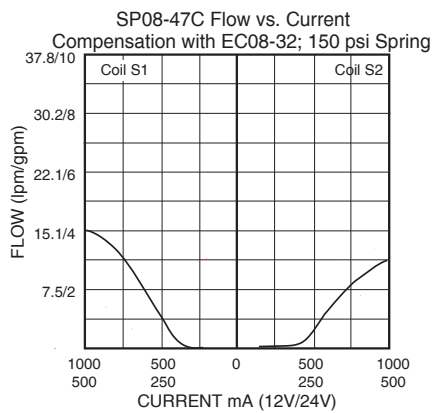
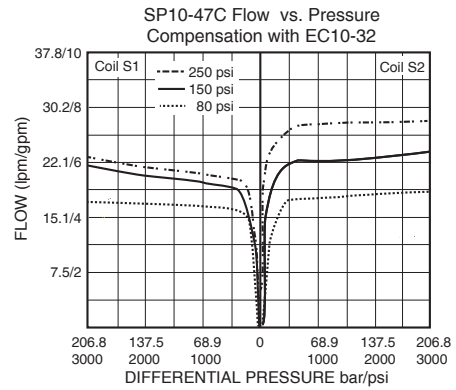
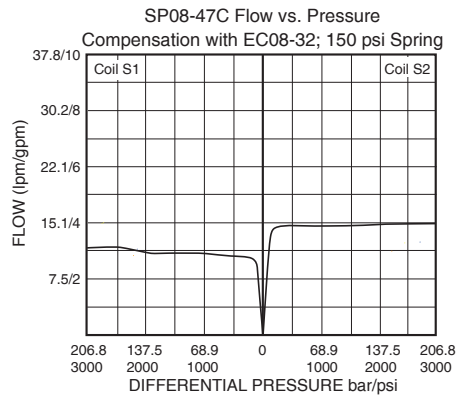
**Coil Duty Rating:** Standard Coils and E-Coils: Continuous up to 115% of nominal voltage

**Oil Viscosity:** 32 cSt/150 sus oil at 40°C (104°F)



# Performance Charts - SPxx-47C

## PERFORMANCE



**Note:** Pressure drop performance is based upon cavity machining and associated port connections machined in accordance with HydraForce cavity specifications. Pressure drop performance is subject to change based on actual manifold/circuit design.

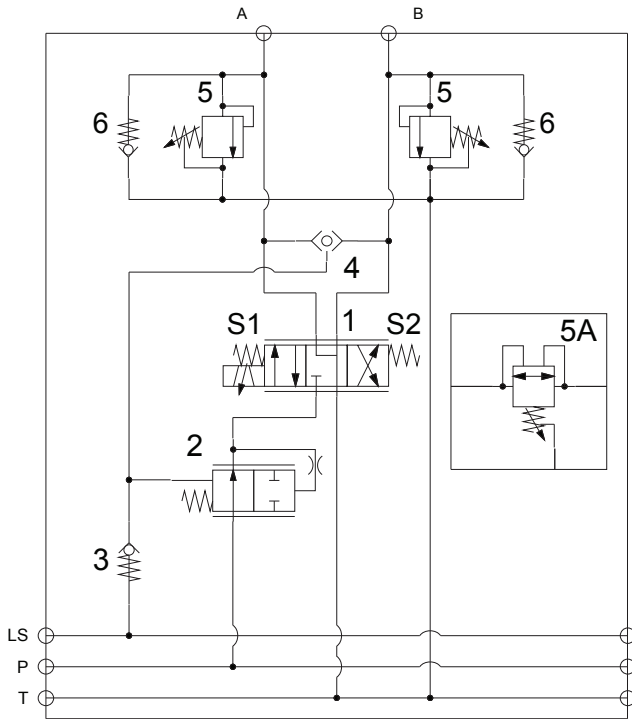
## TO ORDER

To order, refer to ordering information for the individual cartridge valves.

Directional Control Elements	Control Options						
	1	2	3	4	5	5a	6
Flow Rating	Directional Valve	Compensator	Load Sense Check Valve	Load Sense Valve	Pressure Control	Cross-over Relief	Check Valve
11.4 lpm (3.0 gpm)	SP08-47C	EC08-32-0-N-150	HVC06-20-0-U-05	HLS06-B30-X	RV08-20-0-N-XX	CR10-28-0-N-XX	CV08-20-0-N-05
15.5 lpm (4.1 gpm)	SP10-47C	EC10-32-0-N-80					
19.7 lpm (5.2 gpm)		EC10-32-0-N-150					
21.6 lpm (5.7 gpm)		EC10-32-0-N-250					

# Direct-Acting Motor Circuits

## SCHEMATIC



### CARTRIDGE VALVE and PORTING KEY

1	SPxx-47C	5a	CR10-28	A	Work Port A
2	ECxx-32	6	CV08-20	B	Work Port B
3	HCV06-20			LS	Load Sense Port
4	HLS06-30			P	Inlet Port
5	RV08-20			T	Tank

## APPLICATION TIPS

- The **SPxx-47D** ports A and B are connected to tank when in neutral to prevent cavitation of a motor. During the transition, the symmetrical spool provides meter-in/meter-out flow control.
- For stable performance it is recommended to either mount the valve assembly below reservoir level or mount a check valve at the outlet of the manifold to assure oil fills the armature tube of the directional valve.
- SP Series valves are not to be used as the primary load-holding valve. If load-holding is required, use a counter-balance valve or dual-pilot-operated check valve.
- Can be used where no load-holding is required, meter-in meter-out control is desired and unrestricted flow in the neutral position is desired. For example: If the application requires the actuator to free-wheel in the neutral position, the D spool should be used.
- Use a closed loop current controller to ensure that constant current is delivered to the coil regardless of changes in resistance from temperature or voltage fluctuation. Refer to the Coil Operating Parameters chart on page 2.002.1 in the HydraForce Technical Catalog.
- Optimal control signal 100 Hz PWM at maximum dither level
- Electronic controllers optimized for electro-hydraulic integration - visit <http://www.hydraforce.com/ElVeCon/ElVeCon.htm>

## DESCRIPTION

A combination of valves working together to control a bi-directional motor. This direct-acting spool-type product controls flow proportionally in response to a change in current. When the spool is in neutral position, the work ports are open to tank. Valves in this circuit include: **SPxx-47D**, **ECxx-32**, **HLS06-B30**, **RV08-20**, **HCV06-20**, **CV08-20** and an optional **CR10-28**. For applications requiring low work port leakage, the use of a pilot-operated check valve or counter balance valve is suggested.

## OPERATION

When de-energized ports A and B are connected to tank. With power applied to either S1 or S2, flow is allowed to pass from P to either work port depending which coil is powered. The **ECxx-32** assures constant pressure drop across the metering spool. This assures consistent performance regardless of inlet or load conditions.

Features include:

- Port reliefs to limit maximum work port pressure or protect the actuator against sudden shock load (**RV08-20**)
- A single valve cross port relief can be used as an alternative to replace two individual work port relief valves between the work ports. (**CR10-28**)
- Anti-cavitation check valves to ensure the cylinder remains filled with oil. (**CV08-20**)
- Load sense checks valves can be used to allow multiple work sections to be connected in parallel (**HCV06-20**)

## FEATURES

- Ideal for motor applications.
- Continuous duty unitized, molded coil or weather tight IP69 rated E-coil
- Hardened parts for long life.
- Cartridges are voltage interchangeable and easy to service
- Efficient wet-armature construction.
- Choice of compensation values
- Industry-common cavities

## RATINGS

	SP08-47D	SP10-47D
<b>Operating Pressure</b> bar/psi	240 bar/3500 psi	
<b>Flow Rating</b> <b>Spring Size</b> lpm/gpm	<b>150 psi spring</b> 11.0 lpm/2.9 gpm	<b>80 psi spring</b> 16.7 lpm/4.4 gpm <b>150 psi spring</b> 20.5 lpm/5.4 gpm <b>250 psi spring</b> 24.6 lpm/6.5 gpm

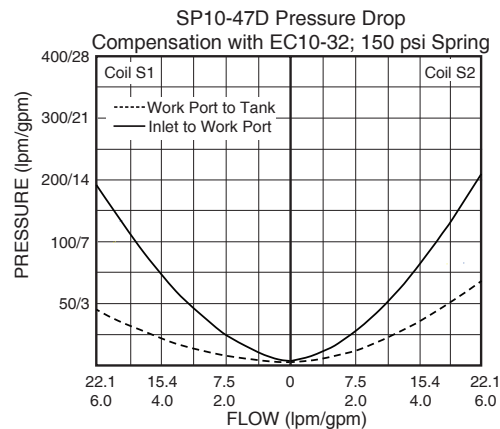
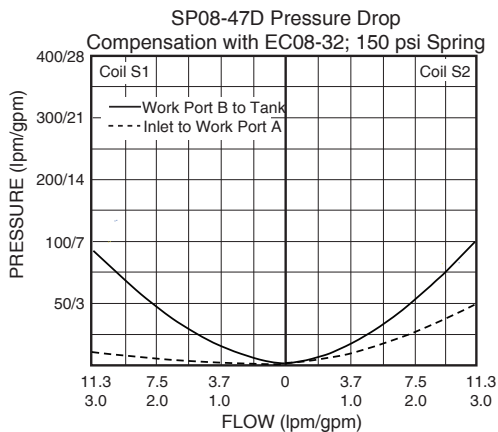
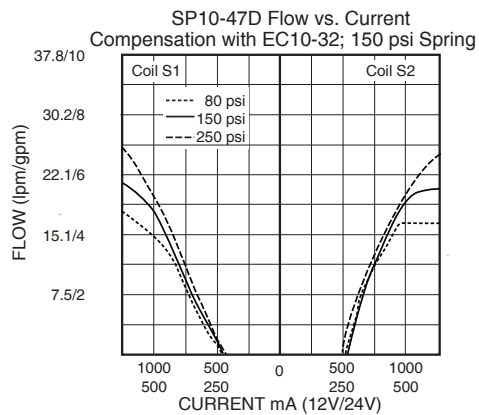
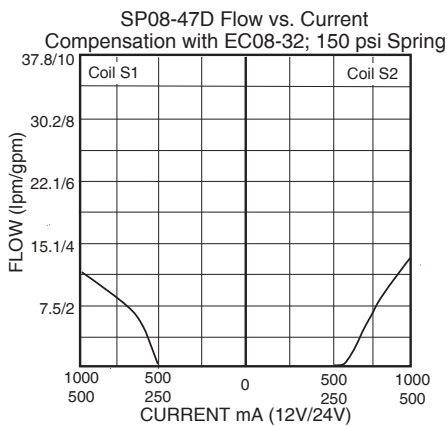
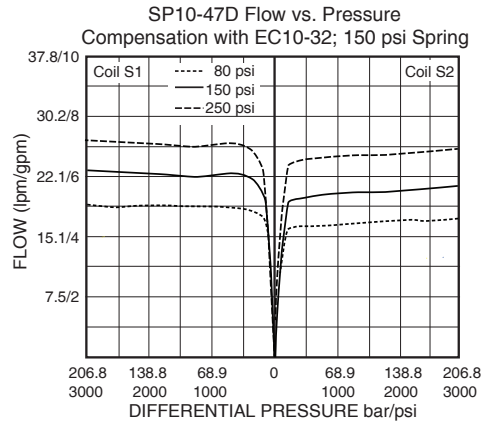
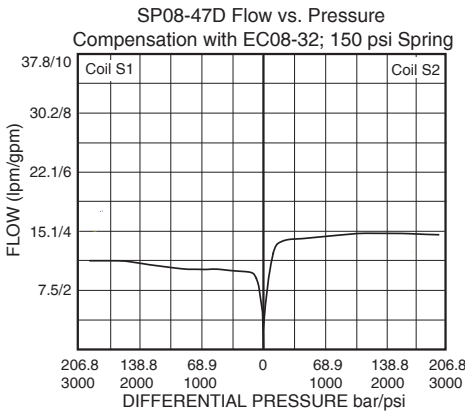
**Hysteresis:** Less than 7%

**Coil Duty Rating:** Standard Coils and E-Coils: Continuous up to 115% of nominal voltage

**Oil Viscosity:** 32 cSt/150 sus oil at 40°C (104°F)

# Performance Charts - SPxx-47D

## PERFORMANCE



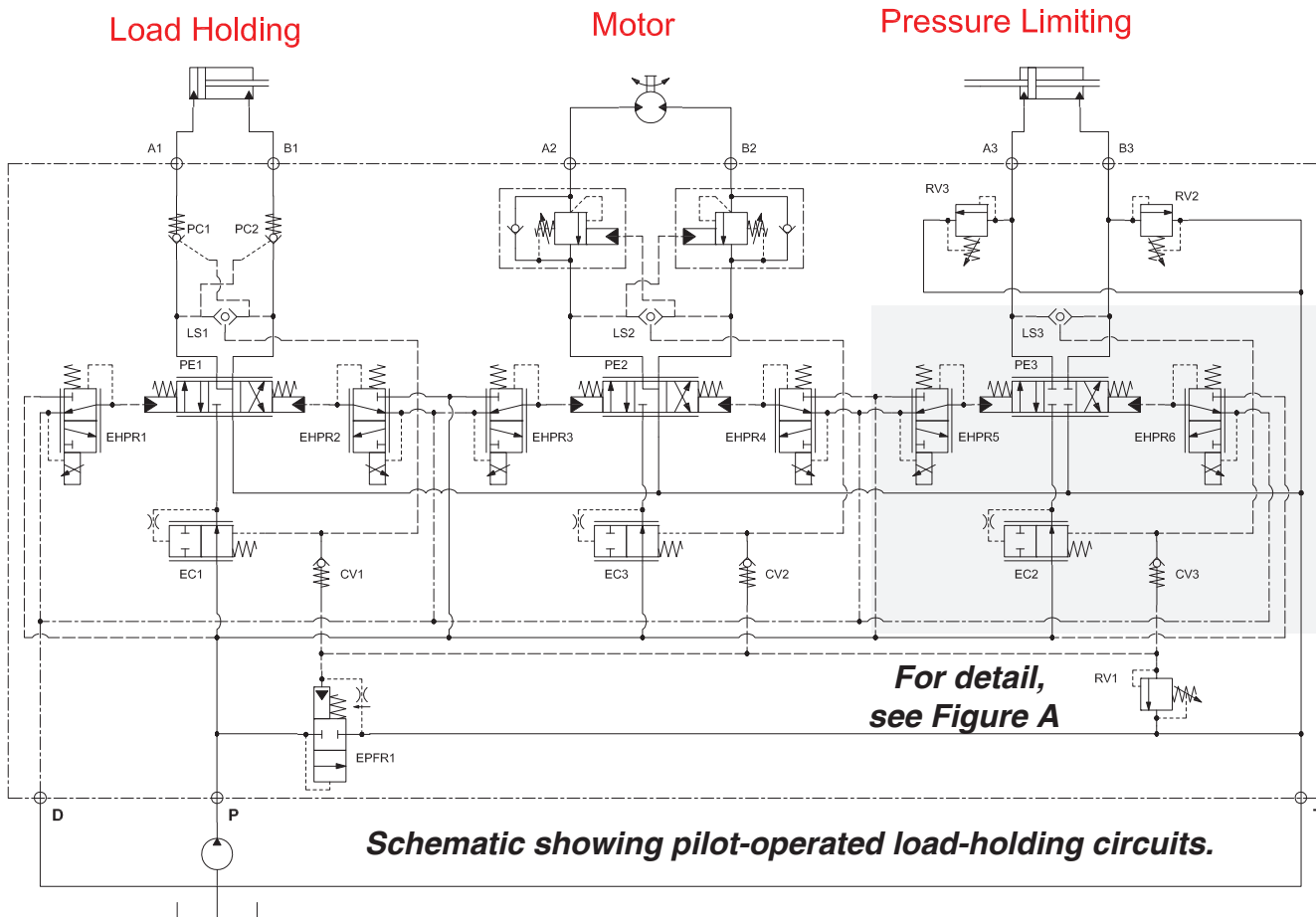
**Note:** Pressure drop performance is based upon cavity machining and associated port connections machined in accordance with HydraForce cavity specifications. Pressure drop performance is subject to change based on actual manifold/circuit design.

## TO ORDER

To order, refer to ordering information for the individual cartridge valves.

Flow Rating	Directional Control Elements		Control Options				
	1	2	3	4	5	5a	6
11.0 lpm (2.9 gpm)	Directional Valve	Compensator	Load Sense Check Valve	Load Sense Valve	Pressure Control	Cross-over Relief	Check Valve
16.7 lpm (4.4 gpm)	SP08-47D	EC08-32-0-N-150	HVC06-20-0-U-05	HLS06-B30-X	RV08-20-0-N-XX	CR10-38x-0-N-XX	CV08-20-0-N-05
20.5 lpm (5.4 gpm)	SP10-47D	EC10-32-0-N-80					
24.6 lpm (6.5 gpm)		EC10-32-0-N-150					
		EC10-32-0-N-250					

# Pilot-Operated Directional Control Valves - Getting Started



Shown above is a load sense system with an inexpensive gear pump and unique HydraForce components, including the PE16-S67 pilot-operated directional control valve, the EHPR electrohydraulic pressure reducing/relieving valve, and the EPFR logic element and flow regulator. Initially, when a load sense system is activated and the operator has **not** selected a function, all flow from the gear pump is diverted to tank through the EPFR bypass compensator. This is efficient, because the only energy consumed is related to the flow from the pump and the bias spring value of the EPFR flow regulator.

When the operator selects a hydraulic function, its respective pressure-reducing/relieving valve (EHPR) valve is energized. For example, as current is applied to the EHPR1 coil, oil flows through EC1, PE1 and finally out through the work ports of either A1 or B1. As the actuator at A1 moves, it imposes a load on the hydraulic system. This load pressure is transmitted through the load shuttle LS1 and continues to the pressure compensator EC1. Load pressure is then conveyed across the load sense network via the load sense check valve (CV3) to the main load sense line.

## Selecting Multiple Functions

When multiple functions are operated simultaneously, only the highest load sense signal is allowed to pass to the main line through one of these check valves. As the load changes, the EPFR1 opens or closes dynamically

in response. This changes the restriction in the pump to tank passage so that less or more flow is available in the hydraulic control circuit. Finally, the maximum system pressure is regulated by the setting of the relief valve, RV1.

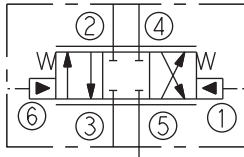
## Three Functions in Operation

One typical operating scenario could be that all three functions are running simultaneously. Assume that the resistance from the load between A2 and B2 is the greatest. The load pressure is transmitted through LS2 and CV4. This pressure acts on EPFR1, which closes in response. The system pressure increases by the pressure required to move the load at port A2 or B2 plus the spring value of EPFR1. As the load pressure requirement increases eventually EPFR1 will close completely and all flow will be available to move the actuators up until the point that the pressure equals that of the setting of RV1. Then pilot pressure will be vented across the RV, allowing the EHPR1 to relieve the pressure to tank.

This system pressure is applied at the inlet of all three work functions. The individual function compensator valves (EC1, EC2 and EC3) will limit this pressure to each function to ensure consistent differential pressure across each PE valve. Thus, the speed at each actuator is controlled based on the opening of the orifice of the spool at the given work function and is not a function of the load pressure.

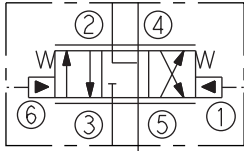


Pilot-operated directional control can be customized for the specific needs of an application with a choice of four valve spool configurations on the main PExx-4x four-way valve.



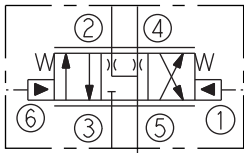
**For Cylinder Applications**  
Meter In/Out

This C spool configuration is ideal for cylinder applications requiring meter-in/meter-out control for a double-acting cylinder.



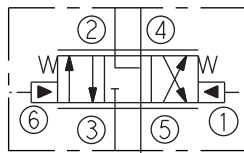
**For Motor Applications**  
Meter In/Out

This D spool configuration is ideal for motor applications requiring meter-in/meter-out control for a hydraulic motor. It is a good choice for applications where no load-holding is required, and unrestricted flow in the neutral position is desired, for example, if the application requires the actuator to free-wheel in neutral.



**For Restricted Motor Applications**  
Meter In/Out

This H spool configuration is ideal for restricted motor applications requiring meter-in/meter-out control for a hydraulic motor, where efficient control of deceleration is desired, or where symmetrical meter-in/meter-out flow control is needed during shift. It can also be used for cylinder applications with bleed-down.



**For Motor Applications**  
Meter In Only

This K spool configuration is ideal for motor applications requiring meter-in only control for a hydraulic motor. It is often used in conjunction with counterbalance valves. The meter-in only characteristic on this spool makes it an idea choice for control of overrunning or over-center loads, since it ensures no back pressure is imposed on the counterbalance valves.

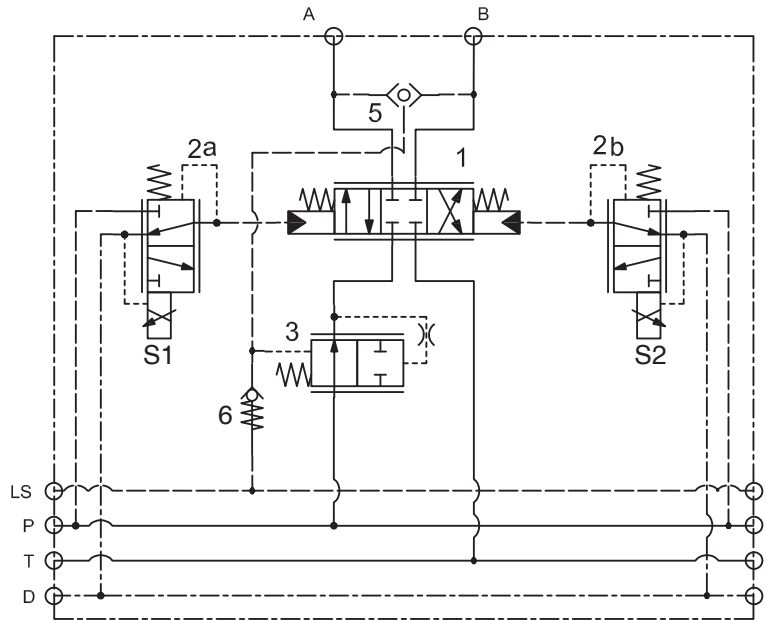
# Theory of Operation

The directional control portion of this circuit consists of a PE16-S67C three-position four-way proportional valve with an EC16-32 flow regulator/pressure compensator and two EHPR98-T35 reducing/relieving valves in combination to form the basis of a closed center, internally compensated load-sensing directional control circuit.

The PE directional valve is piloted by the EHPR valve. When S1 (EHPR1) is energized, flow passes through Work Port A and returns through Work Port B. When S2 (EHPR2) is energized, flow passes through Work Port B and returns through Work Port A.

In **Figure A**, all valves are shown in the neutral (de-energized) position. The pump is not providing flow, so there is no pressure at the inlet.

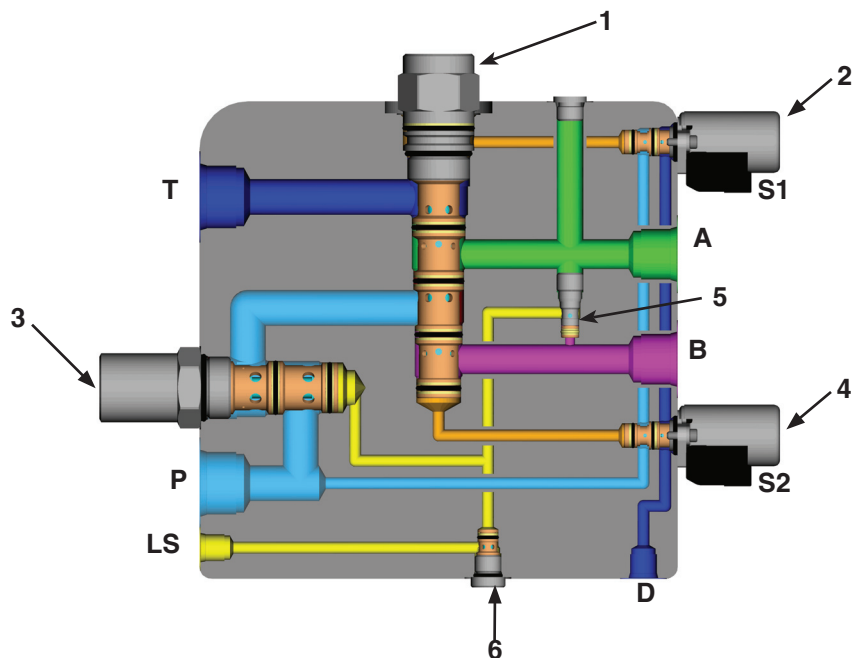
**Schematic showing PExx-67C valve used in a load-sensing application**



***"A PExx-S67C three-position, four-way proportional valve forms the basis of a closed center, pressure-compensated load-sensing directional control valve circuit."***

**CARTRIDGE VALVE and PORTING KEY**

1	PExx-4xx	A	Work Port A
2a	EHPR98-T35	B	Work Port B
2b	EHPR98-T35	LS	Load Sense Port
3	ECxx-32	P	Inlet Port
5	HLS06-30	T	Tank Port
6	HCV06-20	D	Drain Tank
S1	Solenoid 1	S2	Solenoid 2



**FIGURE A - PILOT-OPERATED DIRECTIONAL CONTROL**

**Figure B** illustrates what occurs when S1 (EHPR1) and S2 (EHPR2) coils are both de-energized, and the pump is on while no other functions are active in the circuit.

The main spool of the PE16-S67C directional valve blocks pump flow from entering Work Ports A and B. At the same time, it also blocks flow from exiting the Work Ports and going back to tank.

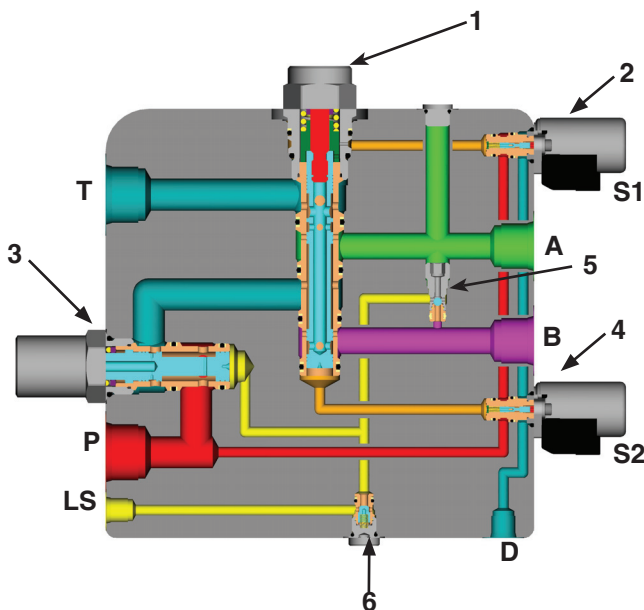
With no flow, the load-induced pressure at the Work Ports acts on the EC16-32 pressure compensator, causing it to shift closed since there's no opposing load sense pressure acting on the spring chamber side of the compensator.

---

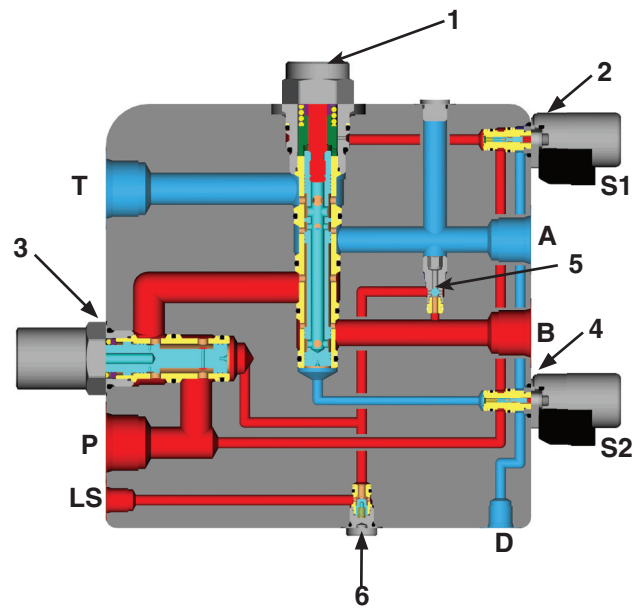
***"Output from the PExx-S67C directional valve is determined by the valve's open area and applied differential pressure between main system pressure and load-induced pressure."***

---

**Figure C** depicts what occurs when S1 (EHPR1) receives an electronic input command. When commanded electro-proportionally, the S1 (EHPR1) provides a pilot pressure signal that shifts the PE16-S67C directional valve from a spring-centered neutral position to an open position. As the pilot pressure from the S1 (EHPR1) valve is increased, the PE16-S67C directional valve starts to meter pump flow out Work Port A to the hydraulic actuator. At the same time, return flow from the hydraulic actuator is metered from Work Port B through the PE16-S67C directional valve back to tank. As pump flow is fed to the hydraulic actuator, the load-induced pressure is sensed by the LS1 shuttle valve, shifting the ball of the shuttle valve into a secondary position. The load sense output pressure from LS1 is communicated to the EC16-32 valve, shifting the compensator into a modulating position. The load-induced pressure demand plus the spring force acting on the compensator spool determines the inlet pressure seen by the pump. The compensator moves in response to changes in load and/or system pressure; thereby regulating the pressure drop across the main directional spool. As long as the hydraulic actuator demands flow, the pressure balance across the compensator is in equilibrium. However, when the load or inlet pressure suddenly changes, the compensator responds accordingly. In other words, flow through the PE16-S67C directional control is determined by the difference between load pressure induced at the actuator in the system and the main system pressure in combination with the restriction of the directional control valve.

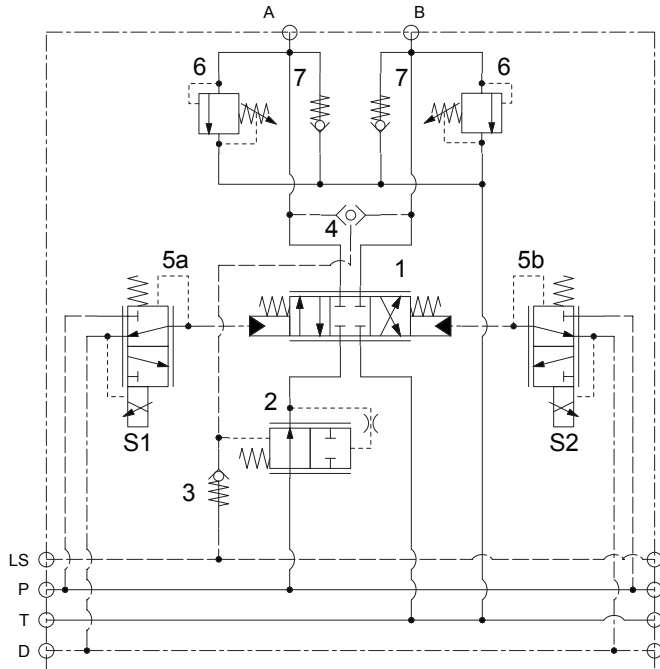


**FIGURE B** - Shown with pump on, coils de-energized and no flow post-compensated. The ECxx-32 compensator regulates pressure of the hydraulic fluid.



**FIGURE C** - Shown energized, when the coils of the PExx-S67C are energized, it works together with the other three valves in a hydraulic manifold circuit.

# Cylinder Circuits, Pilot-Operated, Meter In/Out



## CARTRIDGE VALVE and PORTING KEY

1	PExx-S67C	A	Work Port A
2	ECxx-32	B	Work Port B
3	HCV06-20	LS	Load Sense Port
4	HLS06-30	P	Inlet Port
5a,b	EHPR98-T35	T	Tank
6	RVxx-2x	D	Drain Tank
7	CVxx-20	S1, S2	Solenoid 1, 2

## APPLICATION TIPS

When applying PE valves, as in the circuit above, the following application tips should be taken into consideration:

- When using an EHPR valve, minimize back pressure at port D, as it may prevent the valve from fully shifting. Providing a separate drain line for the EHPR port D is required.
- When using a pilot joystick, the minimum and maximum pilot pressures need to match the PE spool requirement to ensure full spool travel without excessive deadband (i.e. wasted joystick movement.) Maximum pilot pressure can be reduced to limit spool shift and thus limit flow through the PE valve as needed.
- For applications requiring low work port leakage, the use of a pilot-operated check valve or counter balance valve is suggested.
- Optimal control signal 100 Hz PWM at maximum dither level; recommended electronic controllers (see page 2.001.1 in the HydraForce Technical Catalog or our Coretek Product Guide)

## DESCRIPTION

A combination of valves working together to control a double-acting cylinder. This pilot-operated spool-type product controls flow proportionally in response to a change in current.

## OPERATION

When de-energized, no pilot pressure is applied to the PE valve. With power applied to either EHPR1 or EHPR2, flow is allowed to pass from P to either work port. The ECxx-32 ensures constant pressure drop across the metering spool to provide consistent performance regardless of inlet or load conditions. The valve spool is symmetrical, providing meter-in/meter-out control.

Optional features include:

- Port reliefs to limit maximum work port pressure or protect the actuator against sudden shock load.
- Anti-cavitation check valves to ensure the cylinder remains filled with oil in case it is moved by an external force other than the hydraulic pump.
- Load sense checks valves can be used to allow multiple work sections to be connected in parallel.
- A cross port relief can be installed between the work ports to limit the torque or force that the actuator can apply

## FEATURES

- Ideal for double-acting cylinder applications.
- Continuous duty unitized, molded coil or weather tight IP69-rated E-coil
- Hardened parts for long life.
- Cartridges are voltage interchangeable and easy to service
- Efficient wet-armature construction.
- Choice of compensation values
- Industry-common cavities

## RATINGS

	PE12-S67C	PE16-S67C
<b>Operating Pressure</b> bar/psi	240 bar/3500 psi	
<b>Flow Rating</b> lpm/gpm	<b>160 spring</b> 32.2 lpm/8.5 gpm <b>220 spring</b> 36.0 lpm/9.5 gpm	<b>80 spring</b> 49.3 lpm/13.0 gpm <b>160 spring</b> 72.0 lpm/19 gpm <b>200 spring</b> 83.4 lpm/22 gpm

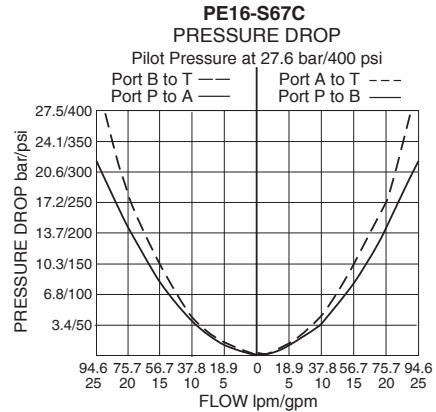
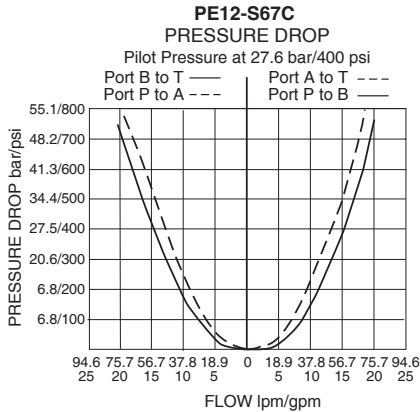
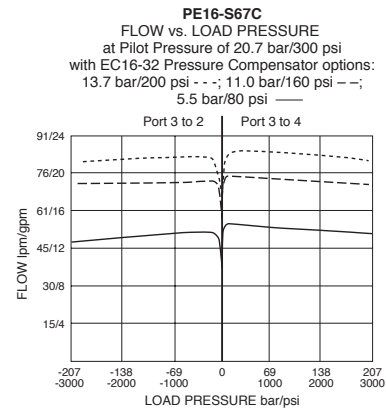
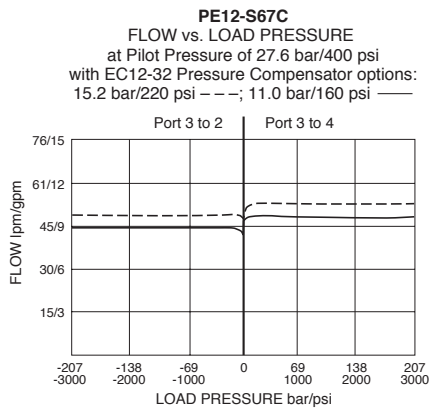
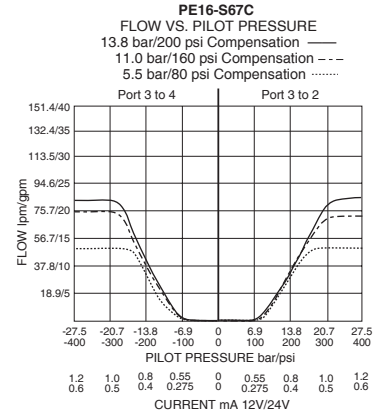
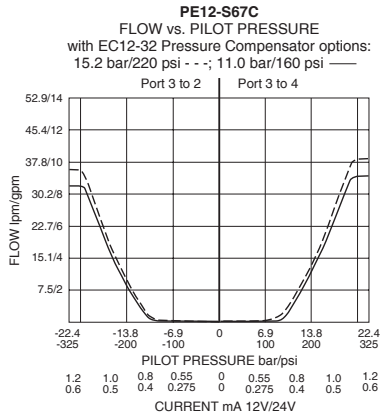
**Hysteresis:** Less than 7%

**Coil Duty Rating:** Continuous up to 115% of nominal voltage

**Oil Viscosity:** 32 cSt/150 sus oil at 40°C (104°F)

# Performance Charts - PExx-S67C

## PERFORMANCE



**Note:** Pressure drop performance is based upon cavity machining and associated port connections machined in accordance with HydraForce cavity specifications. Pressure drop performance is subject to change based on actual manifold/circuit design.

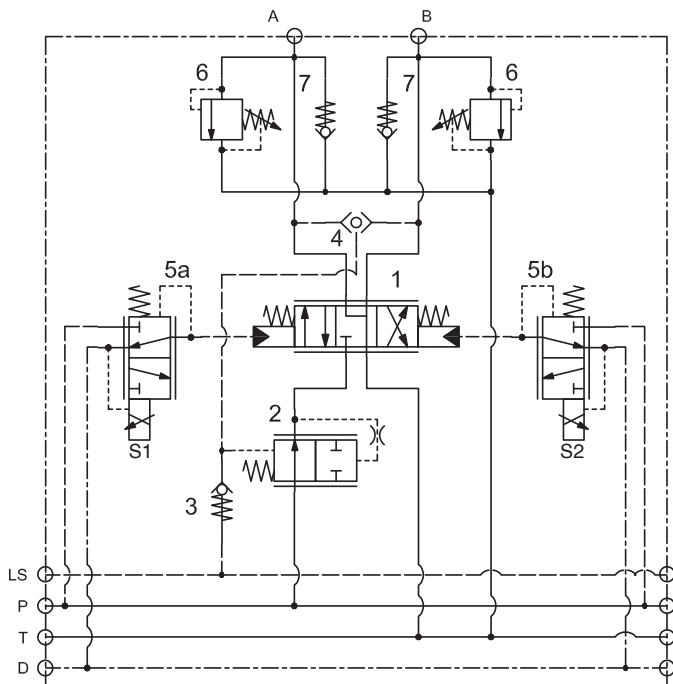
## TO ORDER

To order, refer to ordering information for the individual cartridge valves.

Directional Control Elements			Control Options				
	1	2	3	4	5 a & b	6	7
Flow Rating	Directional Valve	Compensator	Load Sense Check Valve	Load Shuttle	Pressure Reducing/Relieving Valve	Work Port Relief Valves	Anti-Cavitation Check Valve
32.2 lpm/8.5 gpm	PE12-S67C	EC12-32-0-N-160	HCV06-20	HLS06-30	EHPR98-T35	RV08-20	CV10-20
36.0 lpm/9.5 gpm		EC12-32-0-N-220					
49.3 lpm/13 gpm	PE16-S67C	EC16-32-0-N-80					
72.0 lpm/19 gpm		EC16-32-0-N-160					
83.4 lpm/22 gpm		EC16-32-0-N-200					



# Motor Circuits, Pilot-Operated, Meter-In/Out



## CARTRIDGE VALVE and PORTING KEY

1	PExx-S67D	A	Work Port A
2	ECxx-32	B	Work Port B
3	HCV06-20	LS	Load Sense Port
4	HLS06-30	P	Inlet Port
5a,b	EHPR98-T35	T	Tank
6	RVxx-2x	D	Drain Tank
7	CVxx-20	S1, S2	Solenoid 1, 2

## APPLICATION TIPS

When applying PE valves, as in the circuit above, the following application tips should be taken into consideration:

- The D spool is a motor spool that can be used where no load-holding is required, meter-in/meter out control is desired and unrestricted flow in the neutral position is desired. For example, if the application requires the actuator to free-wheel in neutral, D-spool is ideal.
- When using an EHPR valve, minimize back pressure at port D, as it may prevent the valve from fully shifting. Providing a separate drain line for the EHPR port D is required.
- When using a pilot joystick, the minimum and maximum pilot pressures need to match the PE spool requirement to ensure full spool travel without excessive deadband (i.e. wasted joystick movement.) Maximum pilot pressure can be reduced to limit spool shift and thus limit flow through the PE valve as needed.
- For applications requiring low work port leakage, the use of a pilot-operated check valve or counter balance valve is suggested.
- Optimal control signal 100 Hz PWM at maximum dither level; recommended electronic controllers (see page 2.001.1 in the HydraForce Technical Catalog or our Coretek Product Guide)

## DESCRIPTION

A combination of valves working together to control a motor or meter-in/meter-out function. This pilot-operated spool-type product controls flow proportionally in response to a change in current.

## OPERATION

When de-energized, no pilot pressure is applied to the PE valve. With power applied to either EHPR1 or EHPR2, flow is allowed to pass from P to either work port. The ECxx-32 ensures constant pressure drop across the metering spool to provide consistent performance regardless of inlet or load conditions.

Optional features include:

- Port reliefs to limit maximum work port pressure or protect the actuator against sudden shock load.
- Anti-cavitation check valves to ensure the cylinder remains filled with oil in case it is moved by an external force other than the hydraulic pump.
- Load sense checks valves can be used to allow multiple work sections to be connected in parallel.
- A cross port relief can be installed between the work ports to limit the torque or force that the actuator can apply

## FEATURES

- Ideal for motor applications with meter-in, meter-out control.
- Continuous duty unitized, molded coil or weather tight IP69-rated E-coil
- Hardened parts for long life.
- Cartridges are voltage interchangeable and easy to service
- Efficient wet-armature construction.
- Choice of compensation values
- Industry-common cavities

## RATINGS

	PE12-S67D	PE16-S67D
<b>Operating Pressure</b> bar/psi	240 bar/3500 psi	
<b>Flow Rating</b> lpm/gpm	<b>160 spring</b> 42.4 lpm/11.2 gpm	<b>80 spring</b> 49.3 lpm/13.0 gpm
	<b>220 spring</b> 48.5 lpm/12.8 gpm	<b>160 spring</b> 72.0 lpm/19 gpm
		<b>200 spring</b> 77.7 lpm/20.5 gpm

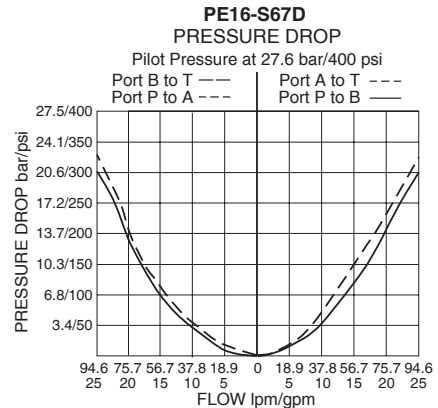
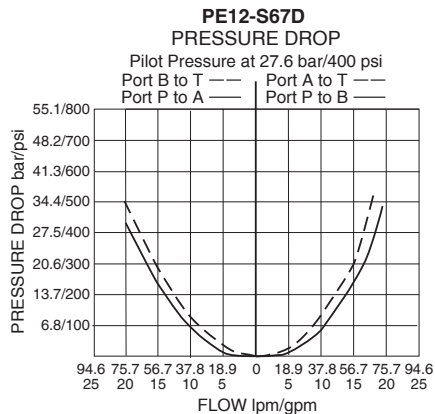
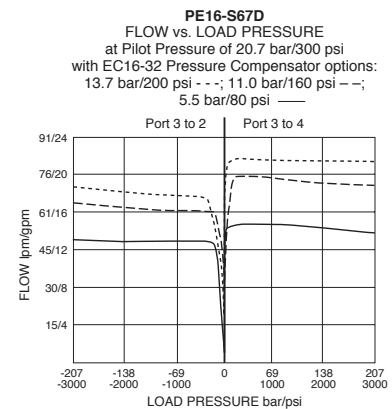
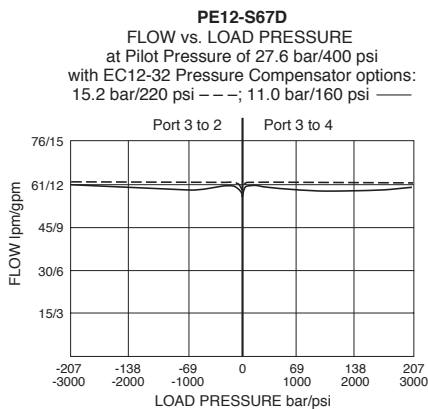
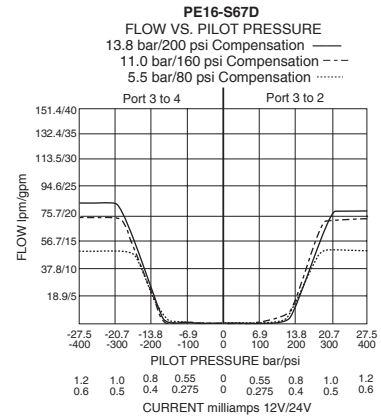
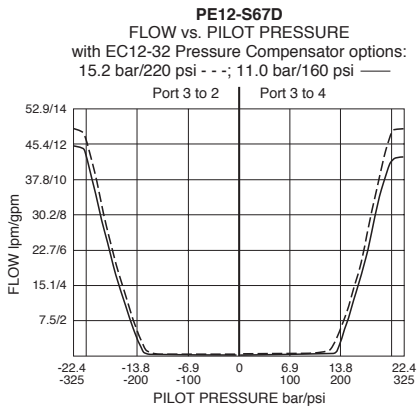
**Hysteresis:** Less than 7%

**Coil Duty Rating:** Continuous up to 115% of nominal voltage

**Oil Viscosity:** 32 cSt/150 sus oil at 40°C (104°F)

# Performance Charts - PExx-S67D

## PERFORMANCE



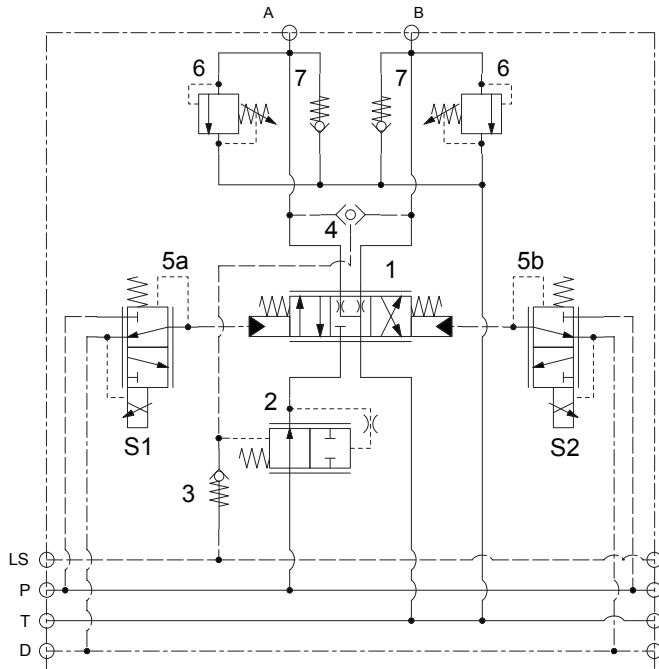
**Note:** Pressure drop performance is based upon cavity machining and associated port connections machined in accordance with HydraForce cavity specifications. Pressure drop performance is subject to change based on actual manifold/circuit design.

### TO ORDER

To order, refer to ordering information for the individual cartridge valves.

Directional Control Elements			Control Options				
	1	2	3	4	5 a & b	6	7
Flow Rating	Directional Valve	Compensator	Load Sense Check Valve	Load Shuttle	Pressure Reducing/Relieving Valve	Work Port Relief Valves	Anti-Cavitation Check Valve
42.4 lpm /11.2 gpm	PE12-S67D	EC12-32-0-N-160	HCV06-20	HLS06-30	EHPR98-T35	RV08-20	CV10-20
48.5 lpm/12.8 gpm		EC12-32-0-N-220					
49.3 lpm/13.0 gpm	PE16-S67D	EC16-32-0-N-80					
72.0 lpm/19.0 gpm		EC16-32-0-N-160					
77.7 lpm/20.5 gpm		EC16-32-0-N-200					

# Motor Circuits, Pilot-Operated, Restricted in Neutral



## CARTRIDGE VALVE and PORTING KEY

1	PExx-S67H	A	Work Port A
2	ECxx-32	B	Work Port B
3	HCV06-20	LS	Load Sense Port
4	HLS06-30	P	Inlet Port
5a,b	EHPR98-T35	T	Tank
6	RVxx-2x	D	Drain Tank
7	CVxx-20	S1, S2	Solenoid 1, 2

## APPLICATION TIPS

When applying PE valves, as in the circuit above, the following application tips should be taken into consideration:

- The H spool is ideal cylinder applications with bleed-down or for motor applications where efficient control of deceleration is desired. It can be used to provide symmetrical meter-in/meter-out flow control during shift.
- When using pilot-operated check valves, the H spool should be used to vent the pilot line to tank to assure the check valves close properly.
- When using an EHPR valve, minimize back pressure at port D, as it may prevent the valve from fully shifting. Providing a separate drain line for the EHPR port D is required.
- When using a pilot joystick, the minimum and maximum pilot pressures need to match the PE spool requirement to ensure full spool travel without excessive deadband (i.e. wasted joystick movement.) Maximum pilot pressure can be reduced to limit spool shift and thus limit flow through the PE valve as needed.
- For applications requiring low work port leakage, a pilot-operated check valve or counter balance valve is suggested.
- Optimal control signal 100 Hz PWM at maximum dither level; recommended electronic controllers (see page 2.001.1 in the HydraForce Technical Catalog or our Coretek Product Guide)

## DESCRIPTION

A combination of valves working together to control deceleration of a motor or symmetrical meter-in/meter-out flow control. This pilot-operated spool-type product controls flow proportionally in response to a change in current.

## OPERATION

When de-energized, no pilot pressure is applied to the PE valve. With power applied to either EHPR1 or EHPR2, flow is allowed to pass from P to either work port. The ECxx-32 ensures constant pressure drop across the metering spool to provide consistent performance regardless of inlet or load conditions.

Optional features include:

- Port reliefs to limit maximum work port pressure or protect the actuator against sudden shock load.
- Anti-cavitation check valves to ensure the cylinder remains filled with oil in case it is moved by an external force other than the hydraulic pump.
- Load sense checks valves can be used to allow multiple work sections to be connected in parallel.
- A cross port relief can be installed between the work ports to limit the torque or force that the actuator can apply

## FEATURES

- Ideal for motor applications that need efficient control of deceleration.
- Continuous duty unitized, molded coil or weather tight IP69-rated E-coil
- Hardened parts for long life.
- Cartridges are voltage interchangeable and easy to service
- Efficient wet-armature construction.
- Choice of compensation values
- Industry-common cavities

## RATINGS

	PE12-S67H	PE16-S67H
<b>Operating Pressure</b> bar/psi	240 bar/3500 psi	
<b>Flow Rating</b> lpm/gpm	<b>160 spring</b> 36.0 lpm/9.5 gpm <b>220 spring</b> 40.9 lpm/10.8 gpm	<b>80 spring</b> 47.4 lpm/12.5 gpm <b>160 spring</b> 68.2 lpm/18.0 gpm <b>200 spring</b> 79.6 lpm/21.0 gpm

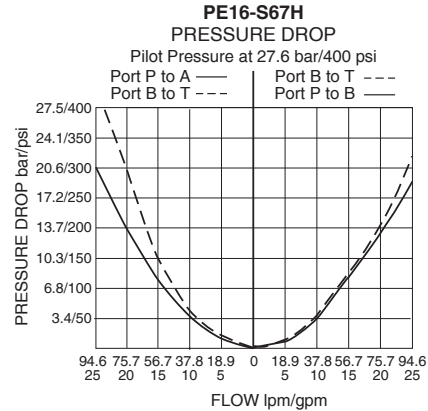
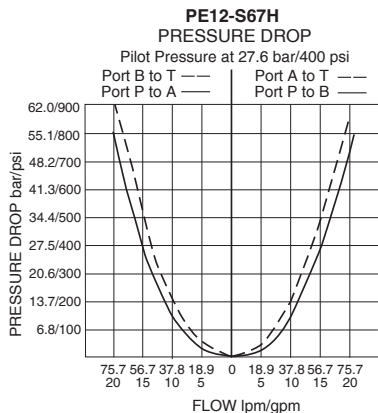
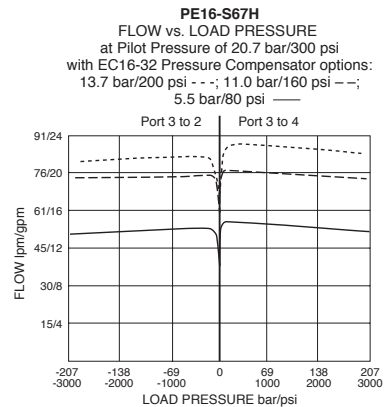
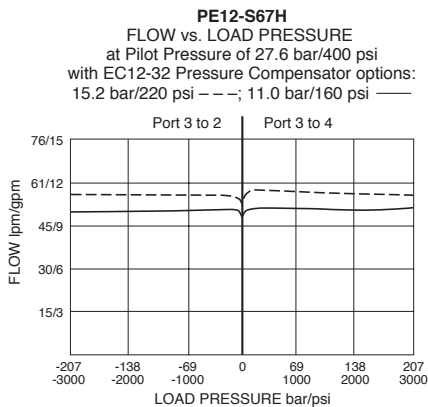
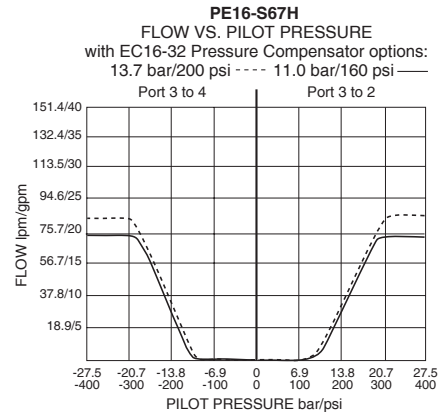
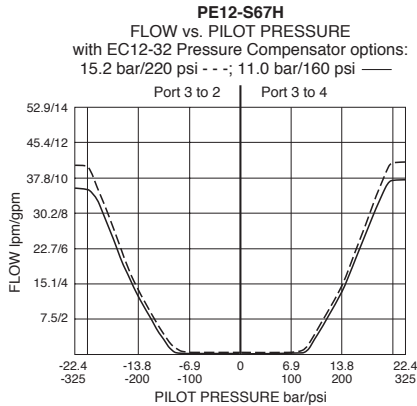
**Hysteresis:** Less than 7%

**Coil Duty Rating:** Continuous up to 115% of nominal voltage

**Oil Viscosity:** 32 cSt/150 sus oil at 40°C (104°F)

# Performance Charts - PExx-S67H

## PERFORMANCE



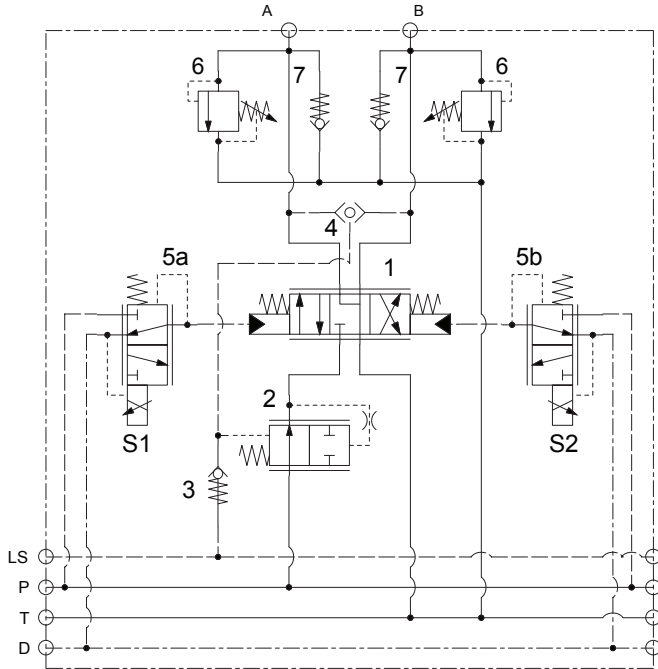
**Note:** Pressure drop performance is based upon cavity machining and associated port connections machined in accordance with HydraForce cavity specifications. Pressure drop performance is subject to change based on actual manifold/circuit design.

## TO ORDER

To order, refer to ordering information for the individual cartridge valves.

Directional Control Elements			Control Options				
	1	2	3	4	5 a & b	6	7
Flow Rating	Directional Valve	Compensator	Load Sense Check Valve	Load Shuttle	Pressure Reducing/Relieving Valve	Work Port Relief Valves	Anti-Cavitation Check Valve
36.0 lpm/9.5 gpm	PE12-S67H	EC12-32-0-N-160	HCV06-20	HLS06-30	EHPR98-T35	RV08-20	CV10-20
40.9 lpm/10.8 gpm		EC12-32-0-N-220					
47.4 lpm/12.5 gpm	PE16-S67H	EC16-32-0-N-80					
68.2 lpm/18.0 gpm		EC16-32-0-N-160					
79.6 lpm/21.0 gpm		EC16-32-0-N-200					

# Motor Circuits, Pilot-Operated, Meter-In Only



## CARTRIDGE VALVE and PORTING KEY

1	PExx-S67K	A	Work Port A
2	ECxx-32	B	Work Port B
3	HCV06-20	LS	Load Sense Port
4	HLS06-30	P	Inlet Port
5a,b	EHPR98-T35	T	Tank
6	RVxx-2x	D	Drain Tank
7	CVxx-20	S1, S2	Solenoid 1, 2

## APPLICATION TIPS

When applying PE valves, as in the circuit above, the following application tips should be taken into consideration:

- The K spool is a motor spool that can be used to provide asymmetrical meter-in only control of flow. When used in conjunction with counterbalance valves, the K spool provides control of overrunning or over-center loads since the meter-in only characteristic ensures that no back pressure is imposed on the counterbalance valves.
- When using an EHPR valve, minimize back pressure at port D, as it may prevent the valve from fully shifting. Providing a separate drain line for the EHPR port D is required.
- When using a pilot joystick, the minimum and maximum pilot pressures need to match the PE spool requirement to ensure full spool travel without excessive deadband (i.e. wasted joystick movement.) Maximum pilot pressure can be reduced to limit spool shift and thus limit flow through the PE valve as needed.
- For applications requiring low work port leakage, the use of a pilot-operated check valve or counter balance valve is suggested.
- Optimal control signal 100 Hz PWM at maximum dither level; recommended electronic controllers (see page 2.001.1 in the HydraForce Technical Catalog or our Coretek Product Guide)

## DESCRIPTION

A combination of valves working together to control a motor with meter-in only control of flow. This pilot-operated spool-type product controls flow proportionally in response to a change in current.

## OPERATION

When de-energized, no pilot pressure is applied to the PE valve. With power applied to either EHPR1 or EHPR2, flow is allowed to pass from P to either work port. The ECxx-32 ensures constant pressure drop across the metering spool to provide consistent performance regardless of inlet or load conditions.

Optional features include:

- Port reliefs to limit maximum work port pressure or protect the actuator against sudden shock load.
- Anti-cavitation check valves to ensure the cylinder remains filled with oil in case it is moved by an external force other than the hydraulic pump.
- Load sense checks valves can be used to allow multiple work sections to be connected in parallel.
- A cross port relief can be installed between the work ports to limit the torque or force that the actuator can apply

## FEATURES

- Ideal for motor and restricted spool applications.
- Continuous duty unitized, molded coil or weather tight IP69-rated E-coil
- Hardened parts for long life.
- Cartridges are voltage interchangeable and easy to service
- Efficient wet-armature construction.
- Choice of compensation values
- Industry-common cavities

## RATINGS

	PE12-S67K	PE16-S67K
<b>Operating Pressure</b> bar/psi	240 bar/3500 psi	
<b>Flow Rating</b> lpm/gpm	<b>160 spring</b> 44.3 lpm/11.7 gpm <b>220 spring</b> 48.9 lpm/12.9 gpm	<b>80 spring</b> 50.4 lpm/13.3 gpm <b>160 spring</b> 72.0 lpm/19.0 gpm <b>200 spring</b> 83.4 lpm/22.0 gpm

**Hysteresis:** Less than 7%

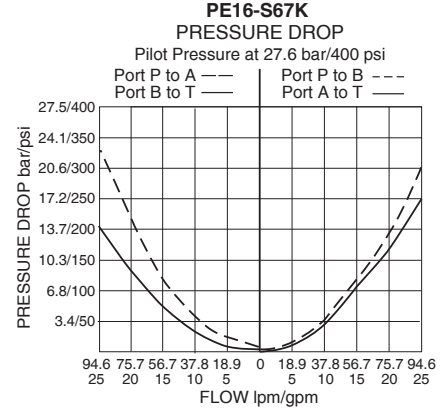
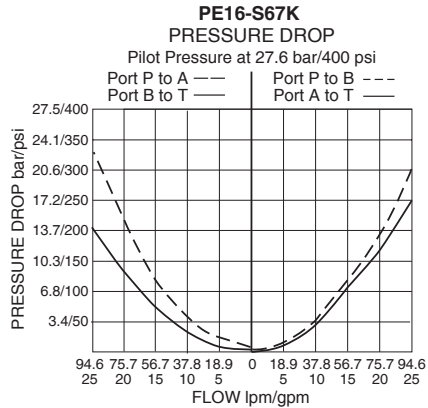
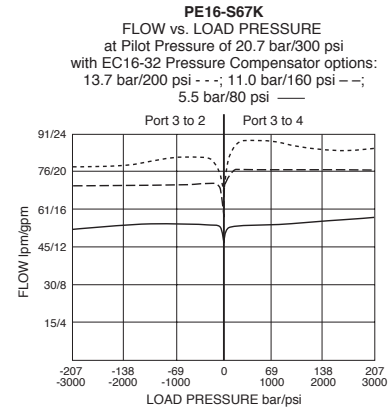
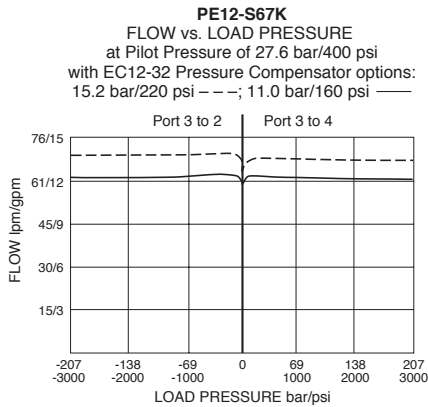
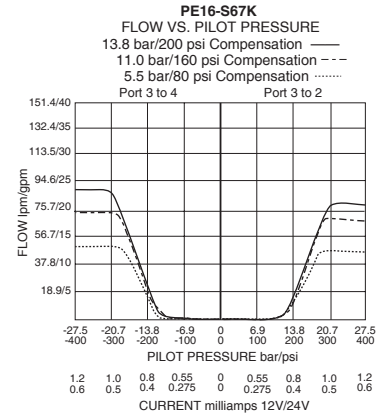
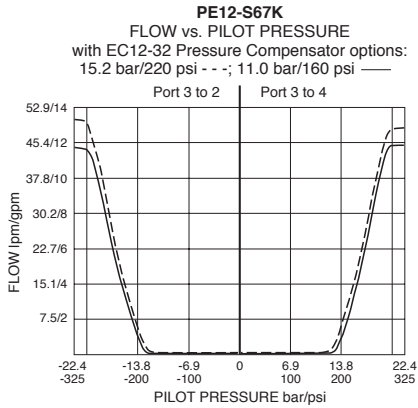
**Coil Duty Rating:** Continuous up to 115% of nominal voltage

**Oil Viscosity:** 32 cSt/150 sus oil at 40°C (104°F)



# Performance Charts - PExx-S67K

## PERFORMANCE



**Note:** Pressure drop performance is based upon cavity machining and associated port connections machined in accordance with HydraForce cavity specifications. Pressure drop performance is subject to change based on actual manifold/circuit design.

## TO ORDER

To order, refer to ordering information for the individual cartridge valves.

Directional Control Elements			Control Options				
	1	2	3	4	5 a & b	6	7
Flow Rating	Directional Valve	Compensator	Load Sense Check Valve	Load Shuttle	Pressure Reducing/Relieving Valve	Work Port Relief Valves	Anti-Cavitation Check Valve
44.3 lpm/11.7 gpm	PE12-S67K	EC12-32-0-N-160	HCV06-20	HLS06-30	EHPR98-T35	RV08-20	CV10-20
48.9 lpm/12.9 gpm		EC12-32-0-N-220					
50.4 lpm /13.3 gpm	PE16-S67K	EC16-32-0-N-80					
72.0 lpm/19.0 gpm		EC16-32-0-N-160					
83.4 lpm/22.0 gpm		EC16-32-0-N-220					



Main headquarters, engineering and manufacturing facility in Lincolnshire Illinois, just north of Chicago.



European headquarters, engineering and manufacturing facility in Birmingham, England.



Precision machining facility in Lincolnshire, Illinois.



Asian/Pacific headquarters, precision machining and manifold assembly facility in Changzhou, China, near Shanghai.

Request our complete engineering catalog, available on CD-ROM or printed edition. Updates and complete technical information are always available on our website: [www.hydraforce.com](http://www.hydraforce.com)

# HYDRAFORCE

Visit our website: [www.hydraforce.com](http://www.hydraforce.com)  
From North America Call Toll Free: 1 800 682 6875

**HYDRAFORCE INC**  
500 Barclay Blvd.  
Lincolnshire, IL 60069  
Phone: 847 793 2300  
Fax: 847 793 0086

Member: National Fluid Power Assoc.  
ISO 9001

**HYDRAFORCE HYDRAULICS LTD**  
St. Stephens Street  
Birmingham B6 4RG England  
Phone: 0121 333 1800  
Fax: 0121 333 1810

Member: British Fluid Power Assoc.  
ISO 9001 & ISO 14001

**HYDRAFORCE HYDRAULIC SYSTEMS (CHANGZHOU) Co., LTD**  
388 W. Huanghe Road, Building 15A  
GDH Changzhou Airport Indl Park  
Xinbei District  
Changzhou, China 213022  
Phone: +86 519 6988 1200  
ISO 9001

**HYDRAFORCE HYDRAULICS – INDIA**  
Vatika Business Centre  
Suite No. 22, Level 5, C Wing  
Techpark One, Airport Road  
Yerwada, Pune 411006  
Maharashtra, India  
Tel: +91 020 40111304  
Fax: +91 020 40111105  
Email: [bharatb@hydraforce.com](mailto:bharatb@hydraforce.com)

**HYDRAFORCE HYDRAULICS LTD**  
Prager Ring 4-12  
D-66482 Zweibrücken, Germany  
Tel: +49 (0) 6332 79 2350  
Mobile: +49 (0) 162 200 1553  
Fax: +49 (0) 6332 79 2359  
Email: [markusb@hydraforce.com](mailto:markusb@hydraforce.com)

**HYDRAFORCE KOREA LLC**  
#306, Mirim Plaza  
1132-1, Jungdong, Wonmigu,  
Bucheon, Kyunggido, Korea  
Tel: +82 32 328 2170  
Fax: +82 32 328 2172  
Email: [jong-seongl@hydraforce.com](mailto:jong-seongl@hydraforce.com)



HydraForce valves meet RoHS environmental requirements restricting the use of cadmium, quick silver, lead hexavalent chrome, polybrominated biphenyl (PPB) or polybrominated diphenyl ester (PPDE) in products, components and packing materials. All HydraForce products meet requirements limiting the use of hazardous materials as identified in OSHA Standard 1910.1200(g).