



**HYDRAFORCE**

POWER FORWARD

# HYDRAFORCE HTD

## HYDRAULIC TORQUE DIVIDER



[www.hydraforce.com](http://www.hydraforce.com)

## KEEP ALL THE WHEELS TURNING

### - not just the one with no traction

Hydrostatic propel systems have their advantages: power density, flexibility, variability. They also have their drawbacks: heat buildup, fluid viscosity, contamination. Every drive application has to **balance the good and the bad**, but this law is immutable: good tractive effort can not exceed the friction between the wheel and the surface.

Flow in **parallel circuits** favors the motor with the lowest pressure drop. Pressure compensated flow dividers can overcome this problem, but these restrictive devices rob power from the system and heat up the fluid. **Series circuits** equalize flow to all motors, but loads are not maintained equally. Uneven loading is a problem that leads to excessive wear and premature failure. Neither circuit type allows motor speed to vary as propel applications require when the vehicle turns a corner.

**You don't have to choose between high pressure drops and uneven loading, HydraForce has a better answer!**

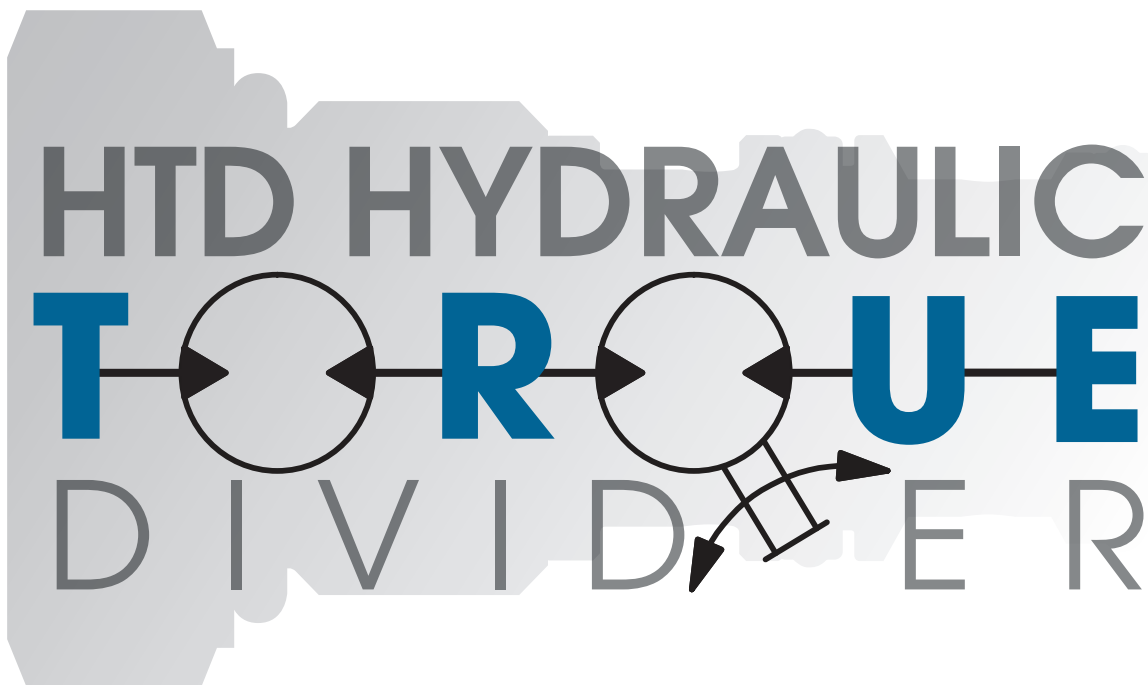

**Balance**  
your series loads  
**Control torque**  
instead of flow

## Control Torque not Flow

You want all the motors in the circuit to **equally share the load**. The HydraForce HTD HyPerformance Torque Divider performs the balancing act. **It's a pressure control** so it manages motor torque: not flow. Applied between two series motors, it **balances the pressure drop** across each motor. This achieves efficient torque division regardless of variation in motor speed.

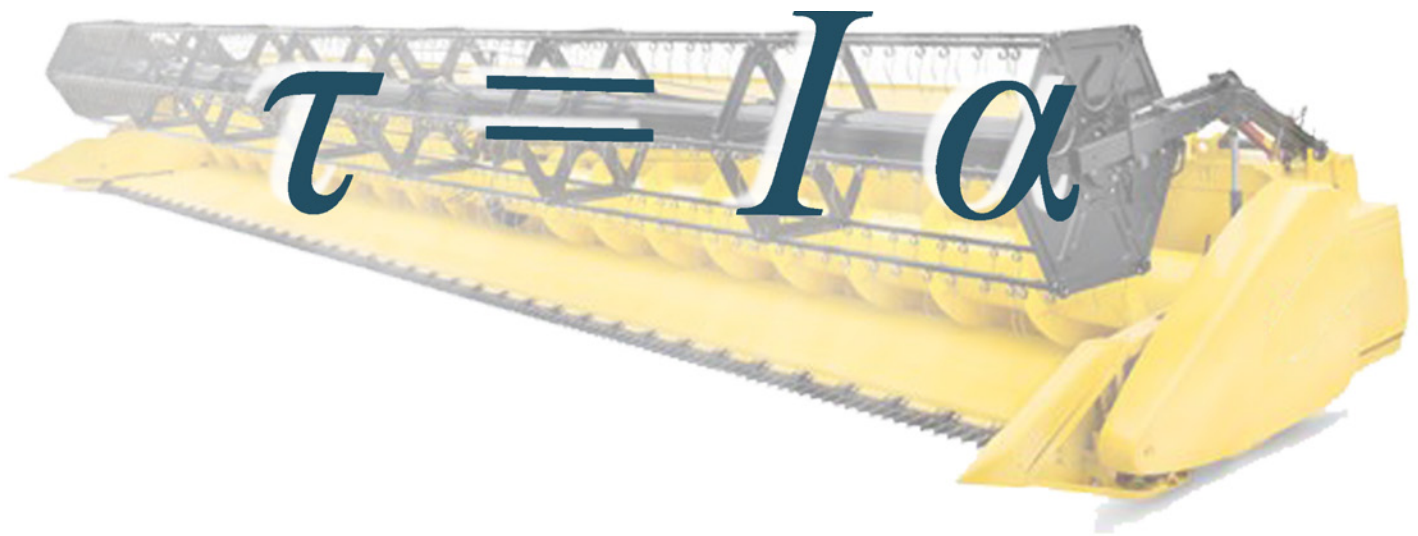

## Turning Vehicle Differential Flows

Flow dividers ensure equal wheel speed regardless of traction. This is not always the performance you want from a traction control. **When the vehicle turns, the inside wheels negotiate a shorter distance than the outside wheels** in the same amount of time. Because both series and parallel (when using flow dividers) arrangements always pass equal flow, this leads to either wheel scuffing that damages both turf and tires, or cavitation as the outside wheel exceeds the flow available.

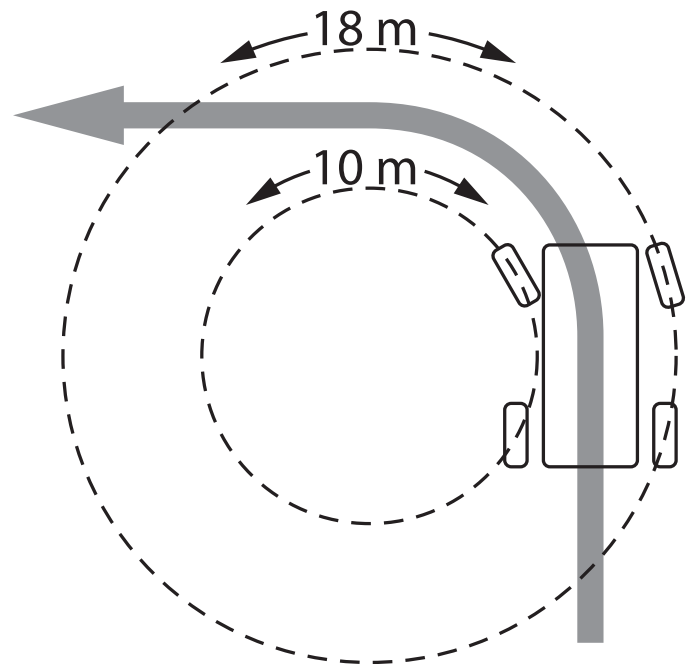

Accommodate  
**TURNING**  
differential

## Size Matters

In a vehicle propel circuit, the HTD valve is **sized to accommodate only the flow difference** between motors when the vehicle is cornering. Driving straight on even terrain, the valve passes no flow. When the vehicle turns a corner, the valve passes a small relief flow, or makeup flow to accommodate the difference in inside/outside wheel speed. Traditional flow dividers must pass flow for the whole drive circuit and this requires larger components.

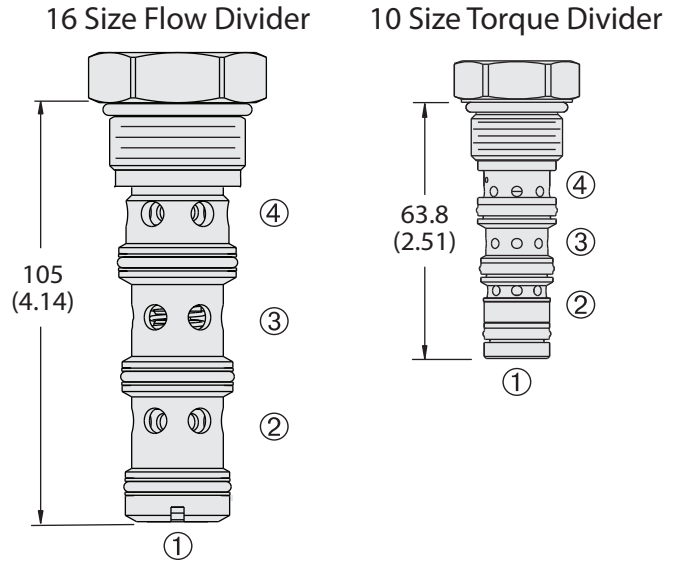

## Keep it Cool

Flow dividers are restrictive flow controls that operate at the cost of pressure drop and they **add heat to the system**. Using a HydraForce HTD Torque Divider eliminates the restriction and heat buildup.

A 100 lpm (26 gpm) four-wheel drive system requires two flow dividers for traction control. These flow dividers do a good job of ensuring all the wheels keep turning, but will consume 3.3 kW (4.4 hp) at full drive speed. This power loss gets converted to **heat in the system**. Hydrostatic drives always generate heat, but if you can **eliminate 3.3 kilowatts (almost 5 horsepower) from your cooling system load**, that is significant.

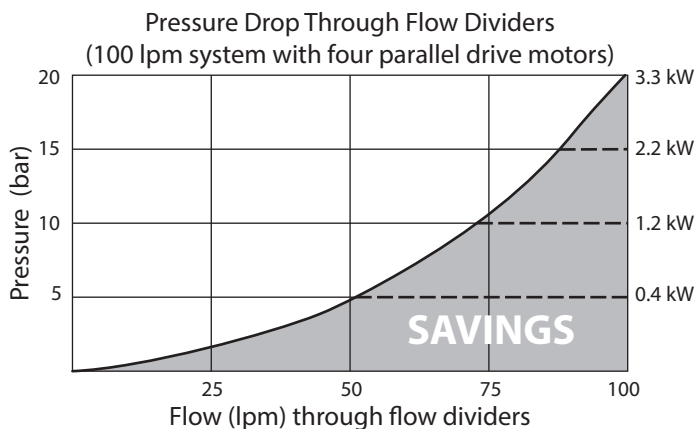
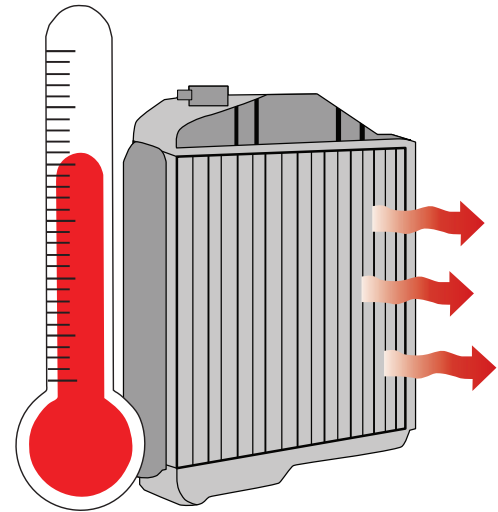

## Save Energy

Studies have shown that flow dividers in a hydrostatic drive circuit are the largest energy wasters in the system. In fact, a 26 gallon per minute four-wheel hydrostatic drive with **flow dividers can waste nearly 5 horsepower** operating the flow dividers. This energy does not propel the vehicle, and it must be removed from the system. This also contributes to the knock-on inefficiencies of a **larger oil reservoir, larger engine, and energy to drive cooling fans**.



# HOW WE DO IT

The **HTD is an internally piloted pressure reducing/relieving valve**. It was developed primarily to address two problems in typical drive circuits that rely on flow dividers for traction control.

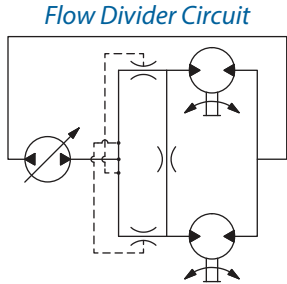

**Efficiency:** HydraForce makes very accurate flow dividers, but the accuracy relies on significant margin pressure. The margin pressure is a net energy waste. In addition, accuracy can suffer at low system flows.

**Steering differential:** Flow dividers provide equal flow to two circuit legs. A turning vehicle requires differential flows to each wheel. Therefore flow divider circuits require an inefficient bypass or *slip* orifice.

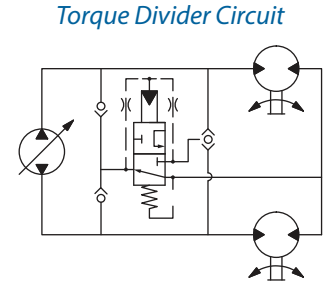

The HTD approaches the issue in a completely different way. **A series motor configuration** provides the primary means of traction control—it keeps all the motors turning. Situated between the two series motors, the HTD allows a small flow into or out of the circuit **allowing the motors to turn at different speeds**. An internal pressure divider network pilots the valve to half the total system pressure, **equally dividing the effective torque**. Alternative ratios, other than 50/50, are possible.

## HTD10-40

The HTD10-40 **regulates to half the total pressure** drop. Alternative ratios are possible.

### Symbol

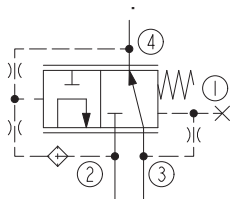

### Performance

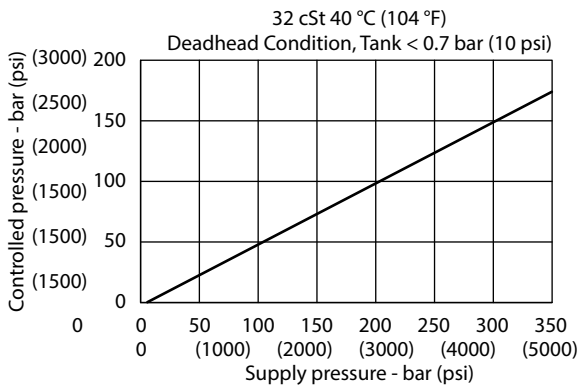

## HTD10-E50 (patent pending)

The five-ported HTD10-50 includes an internal pilot relief that **allows the pilot ratio to change** as circuit pressure increases, such as when the vehicle is driving up a hill.

### Symbol

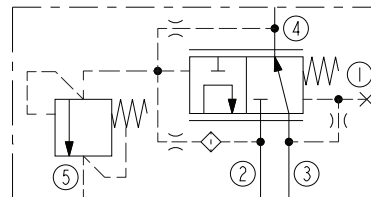

### Performance

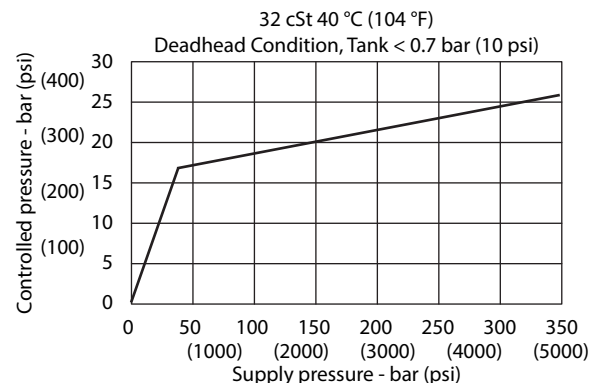

## Testing Manifold - Two Wheel Drive

This pre-designed manifold is available for proving two-wheel drive systems or systems with two series motors. You can easily add to a test vehicle with a few basic plumbing connections. Built for operation with two hydraulic motors in series, one HTD10-40 provides torque control, an adjustable HFR10-32A limits slip in extreme low traction conditions, while four check valves allow bi-directional operation.

**Order number 595C458.**

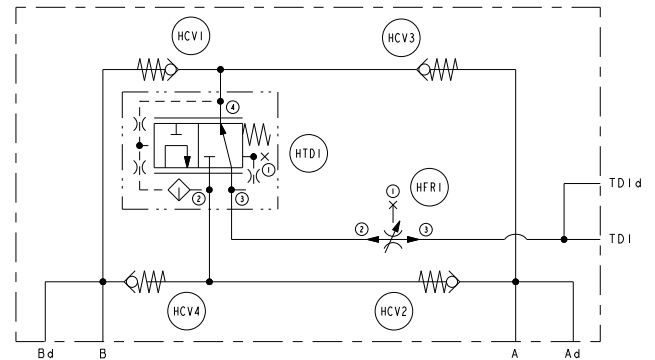
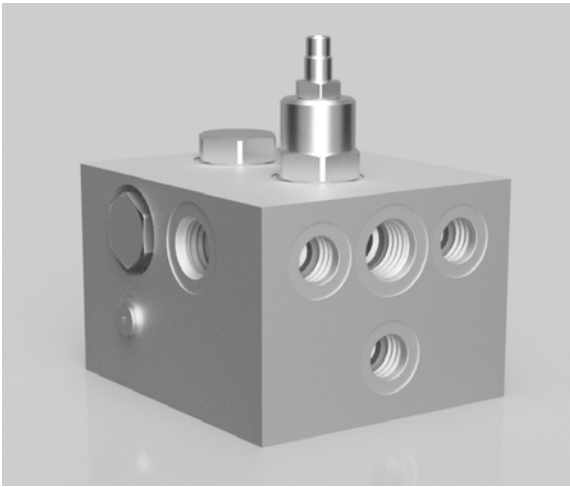

## Testing Manifold - Four Wheel Drive

This pre-designed manifold is available for proving four-wheel drive systems. You can easily add to a test vehicle with a few basic plumbing connections. Built for operation with four wheel cross-over drive configurations (FR-RL/FL-RR), two HTD10-40s provide torque control, one for each parallel section, two adjustable HFR10-32As limit slip in extreme low traction conditions, while four check valves allow bi-directional operation. **Order number 595C459.**

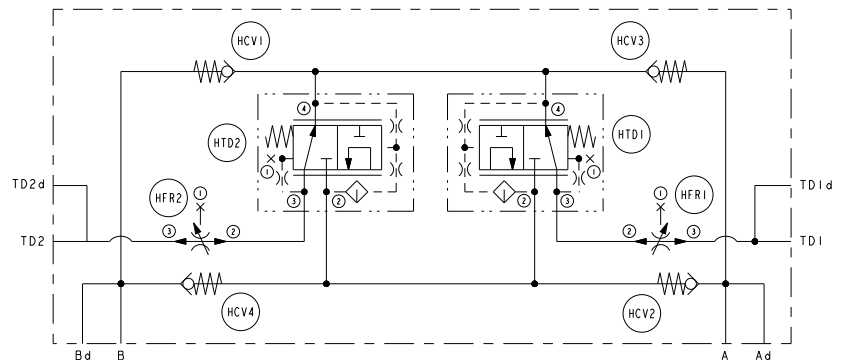

## EXAMPLE APPLICATIONS

### Turfcare

Perfect for fairway mowers with two or four wheel drive, greens mowers, and rollers.



### Specialty Harvesters

With independent four wheel drive, and multiple rotary functions such as shakers and conveyors, HTD has a lot to offer grape and other specialized harvesters.

### Directional Drills

Drills often use motors in series to drive the drill and advance the carriage. HTD ensures balanced loading of all functions.



### The HydraForce HTD Torque Divider:

- Balances motor torque – extending component life
- Reduces the size of your components – saving cost
- Is a simple all-hydraulic solution – requires no electronics
- Operates automatically, on-demand – requires no operator intervention
- Reduces heat buildup – reduce/eliminate cooling systems
- Improves efficiency – smaller engine



# WHY CONSIDER HYDRAFORCE?



- World's largest privately owned cartridge valve manufacturer focused on EH system controls
- Broadest range of cartridge valves
- Designed EH systems for mobile equipment in every industry



- All manifolds are end-of-line function tested
- Use of Lean and Six Sigma practices
- Five year warranty on valves and manifolds



- Free design support
- Simulation software
- Fast prototypes

- Integrate sensors, fittings, ancillary valves, and other custom components into a single manifold
- Simplified circuit design
- Consolidated or distributed hydraulic systems



**RoHS COMPLIANT** HydraForce valve and manifold products comply with the European Council and Parliament RoHS directive 2002/95/EC limiting the use of hazardous substances. For all other products, consult factory.

The content of this document implies no warranty of merchantability or fitness for a particular purpose. This information provides technical illustration only and is not a statement of suitability for any particular application. Each application is unique and we advise you to conduct your own tests and studies to determine the fitness of our products for your application.

© Copyright 2017 HydraForce, Inc. All rights reserved. HydraForce and the HydraForce logo are registered trademarks of HydraForce, Inc.